



Manual for Conducting Order of the Engineer Induction Ceremonies

*November 1, 2011
(Revised January 6, 2013)
(Revised January 29, 2017)
(Revised March 18, 2018)
(Revised April 6, 2018)
(Revised December 24, 2019)
(Revised January 10, 2020)
(Revised October 17, 2020)
(Revised September 27, 2021) (only minor grammatical and formatting changes)*

The Order of the Engineer, Inc.

*“Upholding devotion to the Standards and Dignity of the Engineering Profession”
PO Box 25473, Scottsdale, AZ 85255-0107
Phone: (866) 364-7464
Fax: (480) 585-6418*

Special acknowledgment is given to the Professional Engineers of North Carolina, Link #9, and the University of New Hampshire, Link #148, for their special contributions in the development of this manual. The Sample Script was provided by the Louisiana Tech University, Link #232.



Order of the Engineer Induction Ceremony

Table of Contents

Use of This Manual	i
Preparing for and Conducting an Order of the Engineer Induction Ceremony	ii-iii
Standard Ceremony Planning Timeline	iii
General Outline for a Link Ceremony.....	1
Virtual / Remote Link Ceremonies	2
Virtual Ceremony Planning Timeline	3
University-Centric Ceremony with Suggested Script.....	4
Introduction/Welcome	4
Invocation.....	4
History of The Order.....	5
Significance of the Order	6
Significance of the Ring	7
Acceptance of the Obligation (Oath & Induction)	8
Presentation of the Ring.....	9
Responsibility, Ethics & Obligation.....	10
Commencement Speech (Upon Graduation)	11
Presentation Professionalism/Ethics.....	11
Presentation of Licenses or Certificate.....	12
Concluding Remarks.....	12
Society-Centric Ceremony General Outline	13
Society-Centric Ceremony with Suggested Script (ALTERNATE 1)	14
Introduction/Welcome	14
Invocation.....	14
History of The Order.....	15
Purpose of the Order	17
Significance of the Ring	18
Acceptance of the Obligation (Oath & Induction)	20
Presentation of the Ring.....	20
Professionalism & Ethics.....	21

Concluding Remarks.....	21
Society-Centric Ceremony with Suggested Script (ALTERNATE 2)	23
Introduction/Welcome	23
Invocation.....	23
History of The Order.....	24
Purpose of the Order	26
Significance of the Ring	27
Acceptance of the Obligation (Oath & Induction)	28
Presentation of the Ring.....	29
Professionalism & Ethics.....	30
Concluding Remarks.....	30

Appendices

- A. The Obligation of an Engineer
- B. Supplemental Information –
 - The Origins of “The Order of the Engineer”; An article from *The Professional Engineer*, November/December, 1996, by Kenneth K. Humphreys, P.E., FSNSPE, FPENC.
 - The Fundamental Canons of the NSPE Code of Ethics for Engineers
 - The Engineer’s Creed
- C. Order of the Engineer Ring Ceremony – Alternative Sample Script
- D. Sample Announcements, Programs & Covers
- E. Order of the Engineer Ceremony Materials Order Form
- F. Order of the Engineer Link Information Form
- G. Order of the Engineer Ring Size Order Form
- H. Application for Charter
- I. Ring Replacement Order Form
- J. Sample Certificate – Obligation of an Engineer
- K. Example of Possible Room Layout for Ceremony
- L. Ceremonial Ring for the Order of the Engineer - Specifications



USE OF THIS MANUAL

Dear User of this Manual:

The material contained within this manual has been provided for use by each prospective or current link in the preparation of induction ceremonies for The Order of the Engineer. Included in the materials are specific instructions for conducting a ceremony including sample program documents, mandatory and/or suggested speaker scripts and associated forms that event organizers may find helpful. Sample Ceremony scripts are provided for both University and Professional Society settings, as well as an Alternative Sample Script which represents an abridged version of the Ceremony for situations where time is a factor.

The information and sample documents as presented have been collected by various members of the Board of Governors from a number of sources across the country, and are considered to represent good examples of the true nature and intent of the induction ceremony.

Event organizers are invited to use and modify the sample documents provided herein to suit specific event needs. While it is understood that liberties will be taken in developing each Link's specific program, the mandatory portions of the ceremony must be respected in order to maintain the integrity of the Oath and Obligation of the Engineer.

We wish you all the best of luck in your ongoing endeavors, achievements and professional development. We hope that as engineers, you will approach each challenge with the pride and integrity that honors this great profession.

Sincerely,

The Board of Governors



Preparing for and Conducting an Order of the Engineer Induction Ceremony

(Read these instructions carefully well in advance of the ceremony)

1. Begin promoting the ceremony at least two-months prior to the actual date of the ceremony or the event at which the ceremony is to be held.
2. Per the Code of Regulations, each ceremony shall normally include three (3) current Order members, but no fewer than two (2) to officiate the ceremony. If a link is unable to meet this requirement, upon request, the Board of Governors would be pleased to provide official representation at no cost to the Link.
3. Reserve a room that should be set with a podium and table upon which the large ceremonial ring, and banner if available, is placed as the symbol of the Order.
4. The host of the ceremony is to keep a list of the name of each candidate and his/her ring size. This list of actual participants is to be submitted to the Executive Director of the Order immediately following the ceremony. Participation in the ceremony is mandatory. Within 3 days after the ceremony, the list of inductees, along with the Link Name/Number and location of ceremony should be e-mailed to orderofeng@gmail.com.
5. Arrange a location for candidates to be registered and sized with rings. Ring orders should be placed at least 3-weeks prior to the ceremony and may be ordered on-line. See Appendix G for Ring Order Form.
6. To fit rings, have the candidate determine the approximate ring size using the ring-sizer. The ring is worn on the small finger of the working hand, i.e., the hand with which the candidate normally writes. The ring sizer is only approximate, so it is necessary to try on rings from the supply provided until the correct size is found.
7. The ceremony can be conducted with the candidates putting on their rings in unison at the appropriate time during the ceremony or by each candidate in turn putting his/her hand through the ceremonial ring and having the ring placed on the finger by a member of the installation team. If the first option is used, candidates should be told to put the ring in a pocket or to be kept quickly accessible and not to wear it until being told to do so during the ceremony. If the

second option is used, the ring should be placed in a small envelope marked with the candidate's name.

8. Provide each candidate with a pocket card containing the "Obligation of an Engineer" and suggest that they keep it in their wallet for future reference.
9. Each candidate shall receive a copy of the Obligation to use during the ceremony. These should be reproduced before the ceremony in sufficient quantity. A reproducible copy is included in this manual.
10. The front ceremony table should have the obligation certificates and pens available for use by candidates during the ceremony.
11. For the actual ceremony, the emcee should have other members of the Order to assist, if at all possible. The various members of the team may conduct the parts of the ceremony in turn, e.g., the invocation, the history of the Order, etc.
12. After the ceremony, promptly return the ring box, supplies, and any unpaid fees to host along with the list of initiates and ring sizes so that new rings may be ordered to replace those used during the ceremony.
13. The ceremony is open to the public, friends and family to attend and could be held in conjunction with similar ceremonies for other societies.

Standard Ceremony Planning Timeline

Link Coordinator Responsibilities	Timing	Questions or Need Support? (Contact Individual noted below)
Set ceremony date and reserve a room, review ceremonial manual	8-12 weeks before ceremony	Governor
Start advertising and identify officiants/speakers	8-10 weeks before ceremony	Governor
Finalize inductee list and begin ring sizing	6-8 weeks before ceremony	Governor
Finalize count of rings by size and place order for membership kits and other items *	4-6 weeks before ceremony	Executive Director
Establish outline and script for ceremony with officiants/speakers	2-4 weeks before ceremony	Governor
Develop and print programs, print names on certificates	2-4 weeks before ceremony	Governor
Host ceremony and distribute ceremonial materials to inductees	-	-
Communicate list of inductees to Executive Director *	Within 3 days after ceremony	Executive Director

*Link Coordinators can contact OE Executive Director (Paula Ostaff) either by email (orderofeng@gmail.com) or phone (866-364-7464)



GENERAL OUTLINE FOR A LINK RING CEREMONY

The Order of the Engineer is a solemn obligation to oneself to uphold devotion to the standards and dignity of the engineering profession. It is an obligation to turn to practical use, the principles of sciences and the means of technology and to serve humanity by making the best use of Earth's precious wealth.

Any printed program should be headed with the notations

ORDER OF THE ENGINEER
 Engineer's Ring Ceremony, Link _____
 [Name of Link]
 [Date, Time, and Place]

University-Centric Ceremony

Requirement	Element	Responsibility
Suggested	Welcome	Usually OE Link Governor. May be a Community / school leader.
Optional	Invocation	
Mandatory	History of the Order	Usually an OE Link Governor for that Region. May be any OE Member.
Mandatory	Significance of the Order	Usually an OE Link Governor for that Region. May be any OE Member.
Mandatory	Significance of the Ring	Usually an OE Link Governor for that Region. May be any OE Member.
Mandatory	Acceptance of the Obligation of an Engineer	Candidates (Read Obligation in Entirety)
Mandatory	Presentation of Obligation (certificate) and Ring	Prestigious Member or OE Link Governor
Optional	Engineering: Responsibilities, Ethics & Obligation	Prestigious Member or Leader
Optional	Graduation	University / College
Optional	Commencement Speech	Special Guest / Other
Optional	Presentation on Ethics or Professionalism	Technical Authority/Deans/Department Chairs
Optional	Presentation of Professional License or Certificate (any level)	Representative of Granting Authority
Suggested	Concluding Remarks	MC

VIRTUAL / REMOTE LINK CEREMONIES

At the onset of the COVID-19 Pandemic, the Order of the Engineer sent all Links an Emergency Protocol, allowing the Links to conduct Link Ceremonies in a virtual setting. Prior to March 2020, Link Ceremonies were all conducted face to face, and the Obligation was taken in person. However, University campuses were shut down, and many Links expressed their desire to induct their senior class even though the students were not on campus.

In the interest of promoting public health through social distancing, the Order of the Engineer Emergency Protocol provided guidance to all Links for hosting Virtual Ceremonies, and provided the Links with maximum flexibility to ensure every graduating Engineering student had the opportunity to accept the Obligation of the Engineer. These Emergency Protocols and Guidelines have been adopted for Link use by the Board of Governors, and may be used at any time by any Link in the future, on an as-needed basis in situations where an in-person ceremony is not possible, provided that the essence, meaning and spirit of the traditional ring ceremony is maintained within practical limitations. At a minimum, inductees need to:

- Desire to join the Order
- Read and sign the Obligation Certificate; and
- Place the ring on the fifth finger of their working hand

The Protocols for the Virtual Link Ceremony include:

1. Links should use a video conferencing service or prerecorded video to allow for synchronous or asynchronous remote participation. Any of the major online video conferencing services will promote positive interaction between participants and officials.
2. Links should provide a ring and a certificate to each candidate to allow for remote participation - sending these materials in-advance via mail is suggested.
3. Links should confirm the candidate's participation in the virtual ceremony before sending final participant list to the Executive Director (orderofeng@gmail.com) - requesting an email from the candidates, or a survey submission, are suggested confirmation methods.
4. Links should consider other tactics to maximize ceremony flexibility based on specific Link circumstances - for example, only one current Order member involved in a ceremony (rather than three as specified elsewhere in this Ceremony Manual).

Several Links have recorded and shared their online virtual ceremonies, which are available to view on the Order of the Engineer website at www.order-of-the-engineer.org. Links wishing to conduct a Virtual Ceremony can use these recordings as a reference to see how others have successfully conducted their own ceremonies.

Please see the following timeline to aid in the planning of Virtual Ceremonies:

Virtual Ceremony Planning Timeline

Link Coordinator Responsibilities	Timing	Questions or Need Support? (Contact individual noted below)
Set ceremony date and review ceremonial manual	8-12 weeks before ceremony	Governor
Start advertising and identify officiants/speakers	8-10 weeks before ceremony	Governor
Finalize inductee list (including mailing addresses) and begin ring sizing with printable resource	6-8 weeks before ceremony	Governor
Finalize count of rings by size and place order for membership kits and other items *	4-6 weeks before ceremony	Executive Director
Establish outline and script for virtual ceremony with officiants/speakers	2-4 weeks before ceremony	Governor
Print names on certificates, combine with pocket card and ring, and mail to inductees	2-4 weeks before ceremony	Governor
Host virtual ceremony and capture names of those participating	-	-
Communicate list of inductees to Executive Director *	Within 3 days after ceremony	Executive Director

*Link Coordinators can contact OE Executive Director (Paula [Ostaff](#)) either by email (orderofeng@gmail.com) or phone (866-364-7464)

**UNIVERSITY-CENTRIC
ORDER OF THE ENGINEER CEREMONY SECTIONS
(WITH SUGGESTED SCRIPT)**

INTRODUCTION/WELCOME (Suggested)

IT IS MY PRIVILEGE, ON BEHALF OF THE NATIONAL BOARD OF GOVERNORS OF THE ORDER OF THE ENGINEER TO PRESIDE AND TO WELCOME YOU TO THIS CEREMONY. OTHER MEMBERS OF THE ORDER WHO WILL BE ASSISTING IN THIS CEREMONY ARE:

INVOCATION (Optional)

ETERNAL GOD, MASTER OF THIS STRANGE AND WONDERFUL UNIVERSE, WE ASK YOUR GUIDANCE IN THIS HOUR. WE PRAISE YOU FOR THE RICHES OF CREATION AND FOR THE RESOURCES YOU HAVE PLACED IN OUR HANDS FOR US TO USE AS WE THINK BEST. WE ARE HUMBLLED BY THE SIZE OF THE TASK. LORD, GIVE US DEDICATION AND WISDOM TO MEET OUR OBLIGATION AS ENGINEERS. STRENGTHEN US WHEN THE LOAD SEEMS HEAVIER THAN WE CAN BEAR; LIFT US UP WHEN THINGS GO WRONG; AND HELP US NOT TO BE WEARY IN WELL DOING. UNDER DIVINE GUIDANCE, MAY WE UNDERTAKE SEEMINGLY IMPOSSIBLE PROJECTS, AND ACQUIT OURSELVES WITH HONOR. WE PRAY, TODAY, THAT THE OBLIGATION WE TAKE AND THE STAINLESS STEEL RING WE WEAR MAY BE EVIDENCE OF OUR VISION AND CALLING, AND THAT THIS WORLD MAY BE A HAPPIER AND BETTER PLACE BECAUSE WE CHOOSE TO MAKE IT SO, NOW AND FOR YEARS TO COME.
AMEN.

HISTORY OF THE ORDER (Mandatory)

THIS CEREMONY PRESENTS AN OPPORTUNITY FOR US TO TAKE A PLEDGE AND TO RECALL THAT THE PROFESSIONAL PURPOSE OF ENGINEERING INVOLVES THE PURSUIT OF A LEARNED ART IN THE SPIRIT OF PUBLIC SERVICE. BY FOLLOWING THE ACCEPTANCE OF THE OBLIGATION, THE INDIVIDUAL ENGINEER REINFORCES SIMILAR EFFORTS OF HIS OR HER PEERS, REALIZING THAT IN UNITY THERE IS STRENGTH.

DECADES AGO, OUR ENGINEERING COUNTERPARTS IN CANADA HAD THIS SAME FEELING. THEY BELIEVED THAT A NEED EXISTED FOR THE INTRODUCTION OF A SPIRIT OF BROTHERHOOD AND COHESIVENESS AMONG ENGINEERS. THE CANADIANS BELIEVED THAT A GOOD WAY TO ACHIEVE THIS PURPOSE WOULD BE TO INSTILL IN ENGINEERS, A CONSCIOUSNESS OF BELONGING TO ONE ANOTHER, TO THEMSELVES AS INDIVIDUALS, AND TO THOSE WHOM THEY SERVED. THUS, WHAT WAS DONE IN 1925 IN CANADA IS WHAT IS NOW KNOWN AS: "THE RITUAL OF THE CALLING OF AN ENGINEER." THE WORDS OF THE RITUAL WERE WRITTEN BY THE ENGLISH AUTHOR, RUDYARD KIPLING, WHO HAD MUCH DEPTH OF FEELING FOR ENGINEERS AS THE BUILDERS OF THINGS INTENDED TO BENEFIT MANKIND.

THE CANADIAN CEREMONY IS DIGNIFIED, IMPRESSIVE, AND INCLUDES THE PLACING OF A WROUGHT IRON RING ON THE SMALL FINGER OF THE INDIVIDUAL'S WORKING HAND, AND THEN HAVING THEM REPEAT IN CONCERT THE WORDS OF KIPLING. IT IS DIFFICULT TO VISUALIZE ANY BETTER SYMBOLISM THAN THAT OF A RING, WORN FOR ALL TO SEE, AND SAYING IN EFFECT, THAT HERE IS AN ENGINEER DEDICATED TO A PUBLICLY AVOWED OBLIGATION TO THE PROFESSION AND TO THOSE IT HAS SERVED.

IN OHIO, THE IDEA OF SIMILAR MAXIMS TO THOSE WRITTEN BY KIPLING WERE WELL ESTABLISHED AND CORRESPONDENCE BEGAN IN OCTOBER 1953 BETWEEN THE CANADIAN WARDENS, RESPONSIBLE FOR THE ADMINISTRATION OF THE CALLING OF AN ENGINEER, AND OFFICERS OF THE

OHIO SOCIETY OF PROFESSIONAL ENGINEERS, WITH A VIEW TO POSSIBLY EXTENDING THE CANADIAN CEREMONY TO THE UNITED STATES. DUE TO COPYRIGHT AND OTHER CONFLICTING FACTORS, EXTENSION OF THE RITUAL INTO THIS COUNTRY WAS NOT POSSIBLE.

DURING 1966, A GROUP OF ENGINEERS IN OHIO, WITH MEMBERS OF SEVERAL ENGINEERING ORGANIZATIONS, BEGAN TO PURSUE THE OBJECTIVE OF WHAT CAME TO BE CALLED THE "ORDER OF THE ENGINEER." WHILE THE DELIBERATIONS OF THIS GROUP WERE IN PROGRESS, SENIORS OF FENN COLLEGE OF ENGINEERING OF CLEVELAND STATE UNIVERSITY, COUNSELED BY DEAN BURL BUSH, DESIGNED AND HELD A RING CEREMONY AND RECEPTION ON JUNE 4, 1970. EACH PARTICIPANT SIGNED A CREED AND RECEIVED A PLAIN STAINLESS STEEL RING PLACED ON THE SMALL FINGER OF HIS OR HER WORKING HAND. ONE HUNDRED SEVENTY ENGINEERING SENIORS AND ENGINEERING FACULTY MEMBERS TOOK PART IN THIS FIRST CEREMONY. SINCE THEN, THE MOVEMENT HAS SPREAD RAPIDLY THROUGHOUT THE STATES.

SUCH IS THE STORY OF AN INCREASING ACCEPTANCE OF THE "ORDER OF THE ENGINEER," AS IT IS KNOWN IN THE UNITED STATES TODAY. IT IS PATTERNED ON THE CANADIAN CONCEPT BUT WITH THE STAINLESS STEEL RING SYMBOLIZING STRENGTH AND UNITY OF THE PROFESSION AND PROVIDING AN IDENTIFYING MARK OF AN ENGINEER.

SIGNIFICANCE OF THE ORDER (Mandatory)

THE ORDER OF THE ENGINEER, TO WHICH YOU WILL SOON BELONG, IS AN INDEPENDENT ORGANIZATION. THE PURPOSE IS TO FOSTER A FEELING OF PRIDE IN AND DEDICATION TO THAT PROFESSION WHICH BINDS US TOGETHER.

YOU ARE ASKED TO ACCEPT WITH PRIDE THE MEANING OF THE CEREMONY TO WHICH YOU ARE ABOUT TO SUBSCRIBE. THE “OBLIGATION” SHOULD BE FREELY GIVEN AND THE RESPONSIBILITY GLADLY ACCEPTED.

THE ORDER IS SYMBOLIZED BY THE ACCEPTANCE OF AN “OBLIGATION” AND THE WEARING OF A STAINLESS STEEL RING ON THE LITTLE FINGER OF THE WORKING HAND.

THE OBLIGATION IS THE FORMAL STATEMENT OF AN ENGINEER’S RESPONSIBILITIES TO THE PUBLIC AND TO THE PROFESSION. IT IS A CREED SIMILAR TO THE OATH ATTRIBUTED TO HIPPOCRATES THAT IS COMMONLY TAKEN BY MEDICAL GRADUATES AND WHICH SETS FORTH AN ETHICAL CODE. THE OBLIGATION LIKEWISE CONTAINS PARTS OF THE CANON OF ETHICS OF MAJOR ENGINEERING SOCIETIES. INITIATES, AS THEY VOLUNTARILY ACCEPT IT, PLEDGE TO UPHOLD THE STANDARDS AND DIGNITY OF THE ENGINEERING PROFESSION AND TO SERVE HUMANITY BY MAKING THE BEST USE OF EARTH’S PRECIOUS AND LIMITED RESOURCES. THE “OBLIGATION” IS A COMPOSITE OF SEVERAL CREEDS. IT EMPHASIZES THE FACT THAT WE, AS ENGINEERS, HAVE CERTAIN OBLIGATIONS. IT PROMOTES HONESTY AND INTEGRITY, AND RECOGNIZES THAT TODAY’S ENGINEERS ARE DEPENDENT ON THEIR PREDECESSORS FOR THEIR SKILLS.

SIGNIFICANCE OF THE RING (Mandatory)

THE RING, A SYMBOL OF PRIDE, PRESTIGE, HONOR, AND PROFESSIONALISM AMONG ALL ENGINEERING IN THE UNITED STATES, ALSO SERVES AS A REMINDER TO THE ENGINEER OF OUR OBLIGATION TO SOCIETY.

THE SYMBOL OF YOUR DESIRE TO SERVE THE PUBLIC IS THE ENGINEER’S RING. THE RING YOU WILL WEAR ON THE FIFTH FINGER OF THE WORKING HAND WILL SAY TO ALL WHO SEE IT — HERE IS AN ENGINEER, POSSESSED

OF A PUBLICLY AVOWED DEDICATION TO THE PROFESSION AND THE PUBLIC THEY SERVE.

IT IS OUR SYMBOL – WEAR IT FOR ALL TO SEE. IT IS A BADGE OF RECOGNITION WHICH WILL BECOME KNOWN TO ALL AS THE SIGN OF A LEARNED PROFESSIONAL PLEDGED TO MAKING THE BEST USE OF EARTH'S PRECIOUS AND LIMITED RESOURCES.

ACCEPTANCE OF THE OBLIGATION (Mandatory)

WILL ALL CANDIDATES FOR INDUCTION INTO THE ORDER OF THE ENGINEER PLEASE COME FORWARD AND FACE THE AUDIENCE (DISTRIBUTE COPIES OF THE OBLIGATION TO THE CANDIDATES).

WILL ALL CURRENT MEMBERS OF THE ORDER OF THE ENGINEER PLEASE STAND.

CANDIDATES FOR THE ORDER, THE ORDER OF THE ENGINEER IS AN INDEPENDENT MOVEMENT. THE PURPOSE IS TO FOSTER A FEELING OF PRIDE IN AND DEDICATION TO OUR PROFESSION.

YOUR MEMBERSHIP IN THE ORDER IS SYMBOLIZED BY THE ACCEPTANCE OF AN "OBLIGATION" AND THE WEARING OF THE STAINLESS STEEL RING ON THE LITTLE FINGER OF THE WORKING HAND. THERE ARE NO MEETINGS OTHER THAN THIS CEREMONY, AND THERE ARE NO DUES. IT IS WITH HUMILITY AND THE NEED FOR DIVINE GUIDANCE THAT WE TAKE THIS PLEDGE.

RAISE YOUR RIGHT HAND AND RECITE WITH ME THE "OBLIGATION OF AN ENGINEER".

(Presider & Group read together)

I AM AN ENGINEER. IN MY PROFESSION I TAKE DEEP PRIDE. TO IT I OWE SOLEMN OBLIGATIONS.

AS AN ENGINEER, I PLEDGE TO PRACTICE INTEGRITY AND FAIR DEALING, TOLERANCE AND RESPECT; AND TO UPHOLD DEVOTION TO THE STANDARDS AND THE DIGNITY OF MY PROFESSION, CONSCIOUS ALWAYS THAT MY SKILL CARRIES WITH IT THE OBLIGATION TO SERVE HUMANITY BY MAKING THE BEST USE OF THE EARTH'S PRECIOUS WEALTH.

AS AN ENGINEER, I SHALL PARTICIPATE IN NONE BUT HONEST ENTERPRISES. WHEN NEEDED, MY SKILL AND KNOWLEDGE SHALL BE GIVEN WITHOUT RESERVATION FOR THE PUBLIC GOOD. IN THE PERFORMANCE OF DUTY AND IN FIDELITY TO MY PROFESSION, I SHALL GIVE MY UTMOST.

PRESENTATION OF THE RING (Mandatory)

NOW, IN THE PRESENCE OF YOUR FELLOW ENGINEERS, YOU WILL BE CALLED FORWARD TO SIGN YOUR CERTIFICATE AND RECEIVE YOUR RING AS AN INDICATION OF YOUR ACCEPTANCE OF THE "OBLIGATION" OF THE ORDER OF THE ENGINEER.

YOU WILL THEN PLACE YOUR WORKING HAND THROUGH THE CEREMONIAL RING AND RECEIVE YOUR RING AS THE OUTWARD SIGN OF YOUR PROFESSION.

(After each candidate signs the obligation, they place their hand through the ceremonial ring to receive their engineer's ring. Optionally, depending upon the number of candidates, the signing of certificates can be completed after the ceremony. However, it is important that the Obligation is recited prior to the candidates receiving their rings.)

(LIST NAMES HERE)

1.
2.
3.
4.

RESPONSIBILITY, ETHICS & OBLIGATION (Optional)

FELLOW ENGINEERS, YOU WHO ARE NOW JOINING THE RANKS OF THE PROFESSION AND FOR THOSE CONTINUING YOUR PROFESSIONAL CAREERS, ALLOW ME THE PRIVILEGE OF SAYING THAT WE ARE PROUD TO HAVE YOU WITH US.

WORKING TOGETHER TO STRENGTHEN THE PROFESSIONAL BOND BETWEEN US, AS YOU HAVE JUST DEMONSTRATED, WILL GO A LONG WAY TOWARD GUARANTEEING THE FUTURE OF OUR PROFESSION.

THE ENGINEERING ENVIRONMENT TODAY IS HIGHLY SOPHISTICATED, HIGHLY COMPLEX, AND IS TOTALLY DEMANDING OF OUR INGENUITY TO PROTECT THE ENVIRONMENT AND THE PUBLIC SAFETY, HEALTH, AND WELFARE. ALL THIS, WHILE IMPROVING THE QUALITY OF LIFE.

THE PROFESSION OF ENGINEERING IS NOT AN EASY PATH TO FOLLOW. IT IS A CHALLENGING PROFESSION REQUIRING COMMITMENT TO ETHICS AND EXCELLENCE.

YOUR ENGINEERING EDUCATION WAS/IS THE FIRST ACCOMPLISHMENT IN YOUR PROFESSIONAL CAREER. OTHER RECOMMENDED STEPS ARE AS FOLLOWS:

- **FIRST:** IN YOUR STRIVING TO ADVANCE, CONTINUE YOUR PURSUIT OF TECHNICAL EXCELLENCE. CONTINUE TO STUDY THROUGH FORMAL EDUCATION AND THROUGH GOOD SELF-STUDY PROGRAMS. ENHANCING TECHNICAL PROFICIENCY TODAY IS A MUST. UNIVERSITY CONTINUING EDUCATION PROGRAMS AND PROFESSIONAL WORKSHOPS OFFER THIS OPPORTUNITY.

- **SECOND:** CONTRIBUTE TO YOUR COMMUNITY. SERVE ON PLANNING BOARDS, SCHOOL BOARDS, TOWN COMMITTEES, SERVICE CLUBS, AND IN THE CHAMBER OF COMMERCE-GET INVOLVED!
- **THIRD:** CONTRIBUTE THAT EXTRA 10% EFFORT TO YOUR EMPLOYER. YOU WILL BE SURPRISED WHAT THIS CAN MEAN TO YOU IN YOUR PROFESSIONAL DEVELOPMENT AND PROFESSIONAL RETURNS.
- **FOURTH:** BECOME REGISTERED UNDER THE LAW IN THE STATE WHERE YOU RESIDE. YOU HAVE INVESTED SIGNIFICANT TIME, EFFORT AND FINANCIAL RESOURCES TO OBTAIN AN EDUCATION IN AN ENGINEERING AREA OF SPECIALIZATION. OVER YOUR LONG LIFE, REGISTRATION CAN BE VERY HELPFUL TO YOU IN TERMS OF UPWARD MOBILITY, PROFESSIONAL SUCCESS AND TO CONTRIBUTIONS TO SOCIETY.

FINALLY: JOIN YOUR PROFESSIONAL ORGANIZATION, AICHE, ASCE, ASME, IEEE, SAME AND NSPE OR OTHERS AS APPROPRIATE. THESE SOCIETIES CAN GIVE YOU A GREAT OPPORTUNITY TO STEP UP AND BE COUNTED. THEY WILL HELP SPREAD YOUR PROFESSIONAL WINGS.

SO, ACCEPT MY CONGRATULATIONS FOR A JOB WELL DONE AND MY BEST WISHES FOR A FUTURE CAREER IN WHICH YOU, YOUR UNIVERSITY AND YOUR COLLEAGUES WILL BE PROUD.

COMMENCEMENT SPEECH (FOR GRADUATION ONLY) (Optional)

AS APPROPRIATE IN ASSOCIATION WITH COMMENCEMENT CEREMONY.

PRESENTATION ON PROFESSIONALISM / ETHICS (Optional)

A PRESENTATION ON ETHICS MAY BE MADE IN ASSOCIATION WITH THE CEREMONY, OFTEN DONE BY THE COLLEGE DEAN IF AT AN EDUCATIONAL INSTITUTION.

PRESENTATION ON LICENSES OR CERTIFICATES (Optional)

PRESENTATION OF OTHER CERTIFICATES OR LICENSES MAY BE CONSIDERED AS PART OF THE CEREMONY.

CONCLUDING REMARKS (Suggested)

I WELCOME EACH OF YOU TO THE PRIVILEGES AND THE OBLIGATIONS OF THE ORDER OF THE ENGINEER.

THIS RING IS A REMINDER OF OUR CALLING. YOUR CERTIFICATE IS YOUR CREED. IT BEARS YOUR NAME AND SIGNATURE. IT IS YOUR PACT WITH YOUR PROFESSION. READ IT THOUGHTFULLY. REGARD IT WITH HUMILITY. WEAR YOUR RING PROUDLY AND WITH DISTINCTION FOR YOU ARE AN ENGINEER.

I ASK THE AUDIENCE TO JOIN ME IN CONGRATULATING THE NEWEST MEMBERS OF THE ORDER OF THE ENGINEER. THIS CONCLUDES THE ORDER OF THE ENGINEER CEREMONY. THANK YOU ALL FOR PARTICIPATING.

Society-Centric Ceremony

Requirement	Element	Responsibility
Suggested	Welcome	Usually OE Link Governor, NSPE State or Chapter President.
Optional	Invocation	
Mandatory	History of the Order	Usually an OE Link Governor for that Region. May be any OE Member.
Mandatory	Purpose of the Order	Usually an OE Link Governor for that Region. May be any OE Member.
Mandatory	Significance of the Ring	Usually an OE Link Governor for that Region. May be any OE Member.
Mandatory	Acceptance of the Obligation of an Engineer	Candidates (Read Obligation in Entirety)
Mandatory	Presentation of Obligation (certificate) and Ring	Prestigious Member or OE Link Governor
Optional	Professionalism & Ethics	Prestigious Member or Leader
Suggested	Concluding Remarks	MC

In the Ceremony Program, it is suggested that listings be added for the National Board of Governors and the Local Board of Governors.

Two (2) Society-Centric Ceremony scripts follow. The first script (Alternate 1) involves calling the new inductees forward by name and having the group take the Obligation at the stage while facing the audience. The inductees are then each asked to receive their Ring and Certificate. The second script (Alternate 2) involves the new inductees taking the Obligation while still at their seats, and then they are each called forward by name to receive their Ring and Certificate. The Ceremony length of the Alternate 2 script should be shorter than Alternate 1, since the inductees are called out individually once rather than twice.

**PROFESSIONAL SOCIETY-CENTRIC
ORDER OF THE ENGINEER CEREMONY SECTIONS
(WITH SUGGESTED SCRIPT – ALTERNATE 1)**

INTRODUCTION/WELCOME

(SPEAKER #1): GOOD MORNING/AFTERNOON/EVENING, AND WELCOME TO ALL. MY NAME IS _____ AND I WAS INDUCTED INTO THE ORDER OF THE ENGINEER BY (LINK #__, LINK NAME)

IF SPEAKER #1 IS AN ORDER OF THE ENGINEER GOVERNOR:

(SPEAKER #1): IT IS MY PRIVILEGE, ON BEHALF OF THE NATIONAL BOARD OF GOVERNORS OF THE ORDER OF THE ENGINEER, TO PRESIDE AND WELCOME YOU TO THIS ORDER OF THE ENGINEER CEREMONY.

IF SPEAKER #1 IS NOT AN ORDER OF THE ENGINEER GOVERNOR:

(SPEAKER #1): IT IS MY PRIVILEGE, ON BEHALF OF THE (PROFESSIONAL SOCIETY NAME), TO PRESIDE AND WELCOME YOU TO THIS ORDER OF THE ENGINEER CEREMONY.

OTHER MEMBERS OF THE ORDER WHO WILL BE ASSISTING IN CONDUCTING THIS CEREMONY ARE MY FELLOW COLLEAGUES, (SPEAKER #2) WHO WAS INDUCTED INTO THE ORDER BY (LINK #__, LINK NAME), AND (SPEAKER #3), WHO WAS INDUCTED BY (LINK #__, LINK NAME)

IF PRESENTING AN INVOCATION (OPTIONAL):

(SPEAKER #1): I WOULD LIKE TO NOW CALL UPON (INVOCATION SPEAKER NAME) TO PRESENT AN INVOCATION.

(INVOCATION SPEAKER): ETERNAL GOD, MASTER OF THIS STRANGE AND WONDERFUL UNIVERSE, WE ASK YOUR GUIDANCE IN THIS HOUR. WE PRAISE YOU FOR THE RICHES OF CREATION AND FOR THE RESOURCES YOU HAVE PLACED IN OUR HANDS FOR US TO USE AS WE THINK BEST. WE ARE HUMBLED BY THE SIZE OF THE TASK. LORD, GIVE US DEDICATION AND

WISDOM TO MEET OUR OBLIGATION AS ENGINEERS. STRENGTHEN US WHEN THE LOAD SEEMS HEAVIER THAN WE CAN BEAR; LIFT US UP WHEN THINGS GO WRONG; AND HELP US NOT TO BE WEARY IN WELL DOING. UNDER DIVINE GUIDANCE, MAY WE UNDERTAKE SEEMINGLY IMPOSSIBLE PROJECTS, AND ACQUIT OURSELVES WITH HONOR. WE PRAY, TODAY, THAT THE OBLIGATION WE TAKE AND THE STAINLESS STEEL RING WE WEAR MAY BE EVIDENCES OF OUR VISION AND CALLING, AND THAT THIS WORLD MAY BE A HAPPIER AND BETTER PLACE BECAUSE WE CHOOSE TO MAKE IT SO, NOW AND FOR YEARS TO COME. **AMEN.**

(SPEAKER #1): THANK YOU. THIS MORNING/AFTERNOON/EVENING, WE WILL TELL YOU ABOUT THE HISTORY OF THE ORDER, THE PURPOSE OF THE ORDER, AND THE SIGNIFICANCE OF THE RING. WHEN WE CALL THE INDUCTEES FORWARD, WE ASK THAT YOU BRING YOUR PROGRAM WITH YOU. YOU WILL PUBLICLY TAKE THE OBLIGATION OF THE ENGINEER, AND WE WILL PLACE THE STAINLESS STEEL RING ON THE LITTLE FINGER OF YOUR WORKING HAND. (SPEAKER #2) WILL NOW EXPLAIN THE HISTORY OF THE ORDER.

(SPEAKER #2): HISTORY OF THE ORDER

THIS CEREMONY PRESENTS AN OPPORTUNITY FOR US TO TAKE A PLEDGE AND TO RECALL THAT THE PROFESSIONAL PURPOSE OF ENGINEERING INVOLVES THE PURSUIT OF A LEARNED ART IN THE SPIRIT OF PUBLIC SERVICE. BY FOLLOWING THE ACCEPTANCE OF THE OBLIGATION, THE INDIVIDUAL ENGINEER REINFORCES SIMILAR EFFORTS OF HIS OR HER PEERS, REALIZING THAT IN UNITY THERE IS STRENGTH.

DECADES AGO, OUR ENGINEERING COUNTERPARTS IN CANADA HAD THIS SAME FEELING. THEY BELIEVED THAT A NEED EXISTED FOR THE INTRODUCTION OF A SPIRIT OF BROTHERHOOD AND COHESIVENESS AMONG ENGINEERS. THE CANADIANS BELIEVED THAT A GOOD WAY TO ACHIEVE THIS PURPOSE WOULD BE TO INSTILL IN ENGINEERS A CONSCIOUSNESS OF

BELONGING TO ONE ANOTHER, TO THEMSELVES AS INDIVIDUALS, AND TO THOSE WHOM THEY SERVED.

THUS, WHAT WAS DONE IN 1925 IN CANADA IS WHAT IS NOW KNOWN AS: "THE RITUAL OF THE CALLING OF AN ENGINEER." THE WORDS OF THE RITUAL WERE WRITTEN BY THE ENGLISH AUTHOR, RUDYARD KIPLING, WHO HAD MUCH DEPTH OF FEELING FOR ENGINEERS AS THE BUILDERS OF THINGS INTENDED TO BENEFIT MANKIND.

THE CANADIAN CEREMONY IS DIGNIFIED, IMPRESSIVE, AND INCLUDES THE PLACING OF A WROUGHT IRON RING ON THE SMALL FINGER OF THE INDIVIDUAL'S WORKING HAND, AND THEN HAVING THEM REPEAT IN CONCERT THE WORDS OF KIPLING. IT IS DIFFICULT TO VISUALIZE ANY BETTER SYMBOLISM THAN THAT OF A RING, WORN FOR ALL TO SEE, AND SAYING IN EFFECT, THAT HERE IS AN ENGINEER DEDICATED TO A PUBLICLY AVOWED OBLIGATION TO THE PROFESSION AND TO THOSE IT HAS SERVED. IN OHIO, THE IDEA OF SIMILAR MAXIMS TO THOSE WRITTEN BY KIPLING WERE WELL ESTABLISHED AND CORRESPONDENCE BEGAN IN OCTOBER 1953 BETWEEN THE CANADIAN WARDENS, RESPONSIBLE FOR THE ADMINISTRATION OF THE CALLING OF AN ENGINEER, AND OFFICERS OF THE OHIO SOCIETY OF PROFESSIONAL ENGINEERS, WITH A VIEW TO POSSIBLY EXTENDING THE CANADIAN CEREMONY TO THE UNITED STATES.

DUE TO COPYRIGHT AND OTHER CONFLICTING FACTORS, EXTENSION OF THE RITUAL INTO THIS COUNTRY WAS NOT POSSIBLE. DURING 1966, A GROUP OF ENGINEERS IN OHIO, WITH MEMBERS OF SEVERAL ENGINEERING ORGANIZATIONS, BEGAN TO PURSUE THE OBJECTIVE OF WHAT CAME TO BE CALLED THE "ORDER OF THE ENGINEER."

WHILE THE DELIBERATIONS OF THIS GROUP WERE IN PROGRESS, SENIORS OF FENN COLLEGE OF ENGINEERING AT CLEVELAND STATE UNIVERSITY, COUNSELED BY DEAN BURL BUSH, DESIGNED AND HELD A RING CEREMONY AND RECEPTION ON JUNE 4, 1970. EACH PARTICIPANT SIGNED A CREED AND

RECEIVED A PLAIN STAINLESS STEEL RING PLACED ON THE SMALL FINGER OF HIS OR HER WORKING HAND. ONE HUNDRED SEVENTY ENGINEERING SENIORS AND ENGINEERING FACULTY MEMBERS TOOK PART IN THIS FIRST CEREMONY. SINCE THEN, THE ORDER HAS GROWN TO INCLUDE TENS OF THOUSANDS OF MEMBERS INDUCTED AT LINKS (LOCAL CHAPTERS) ESTABLISHED IN NEARLY EVERY STATE IN THE UNION. ALTHOUGH PATTERNED AFTER THE CANADIAN CONCEPT, THE ORDER OF THE ENGINEER HAS DIFFERENCES THAT ARE DISTINCTIVELY ASSOCIATED WITH THE UNITED STATES OF AMERICA. WE ASK THAT YOU ACCEPT WITH PRIDE THE MEANING AND PURPOSE OF THE CEREMONY IN WHICH YOU ARE ABOUT TO PARTICIPATE: TO UPHOLD THE STANDARDS AND INTEGRITY OF THE ENGINEERING PROFESSION.

(SPEAKER #3) WILL NOW TELL US ABOUT THE PURPOSE OF THE ORDER...

(SPEAKER #3): PURPOSE OF THE ORDER

THE ORDER OF THE ENGINEER, TO WHICH YOU WILL SOON BELONG, IS AN INDEPENDENT ORGANIZATION. THE PURPOSE IS TO FOSTER A FEELING OF PRIDE IN AND DEDICATION TO THAT PROFESSION WHICH BINDS US TOGETHER.

YOU ARE ASKED TO ACCEPT WITH PRIDE THE MEANING OF THE CEREMONY TO WHICH YOU ARE ABOUT TO SUBSCRIBE. THE "OBLIGATION" SHOULD BE FREELY GIVEN AND THE RESPONSIBILITY GLADLY ACCEPTED. THE ORDER IS SYMBOLIZED BY THE ACCEPTANCE OF AN "OBLIGATION" AND THE WEARING OF A STAINLESS STEEL RING ON THE LITTLE FINGER OF THE WORKING HAND.

THE OBLIGATION IS THE FORMAL STATEMENT OF AN ENGINEER'S RESPONSIBILITIES TO THE PUBLIC AND TO THE PROFESSION. IT IS A CREED SIMILAR TO THE OATH ATTRIBUTED TO HIPPOCRATES THAT IS COMMONLY TAKEN BY MEDICAL GRADUATES AND WHICH SETS FORTH AN ETHICAL CODE.

THE OBLIGATION LIKEWISE CONTAINS PARTS OF THE CANON OF ETHICS OF MAJOR ENGINEERING SOCIETIES.

INITIATES, AS THEY VOLUNTARILY ACCEPT IT, PLEDGE TO UPHOLD THE STANDARDS AND DIGNITY OF THE ENGINEERING PROFESSION AND TO SERVE HUMANITY BY MAKING THE BEST USE OF EARTH'S PRECIOUS AND LIMITED RESOURCES. THE "OBLIGATION" IS A COMPOSITE OF SEVERAL CREEDS. IT EMPHASIZES THE FACT THAT WE, AS ENGINEERS, HAVE CERTAIN OBLIGATIONS. IT PROMOTES HONESTY AND INTEGRITY AND RECOGNIZES THAT TODAY'S ENGINEERS ARE DEPENDENT ON THEIR PREDECESSORS FOR THEIR SKILLS.

I NOW CALL UPON (SPEAKER #1) TO DISCUSS THE SIGNIFICANCE OF THE RING.

SIGNIFICANCE OF THE RING

(SPEAKER #1): I WILL NOW SHARE THE SIGNIFICANCE OF THE RING.

THE RING, A SYMBOL OF PRIDE, PRESTIGE, HONOR, AND PROFESSIONALISM AMONG ALL ENGINEERS IN THE UNITED STATES, ALSO SERVES AS A REMINDER OF OUR OBLIGATION TO SOCIETY.

THE SIGNIFICANCE OF WHAT YOU ARE ABOUT TO SAY AND DO MIGHT BE EXPRESSED THIS WAY:

- I AM AN ENGINEER
- I HAVE AN OBLIGATION TO MY PROFESSION
- MY DESIRE IS TO APPLY THE GOLDEN RULE, OUR CODE OF ETHICS, TO THE PRACTICE OF MY PROFESSION
- MY OBLIGATION IS THE YARDSTICK OF MY PROFESSIONALISM
- MY PROFESSIONALISM MEANS TO ME THAT I WILL NEVER ASK MYSELF THE QUESTION "HOW MUCH DO I GET OUT OF IT?" BUT RATHER, I WILL ASK "HOW MUCH CAN I GIVE?"

THE SYMBOL OF YOUR DESIRE TO SERVE THE PUBLIC IS THE ENGINEER'S RING. THE RING YOU WILL WEAR ON THE FIFTH FINGER OF THE WORKING HAND WILL SAY TO ALL WHO SEE IT — HERE IS AN ENGINEER, POSSESSED OF A PUBLICLY AVOWED DEDICATION TO THE PROFESSION AND THE PUBLIC THEY SERVE. IT IS OUR SYMBOL – WEAR IT FOR ALL TO SEE. THE RING IS A BADGE OF RECOGNITION WHICH WILL BECOME KNOWN TO ALL AS THE SIGN OF A LEARNED PROFESSIONAL PLEDGED TO MAKING THE BEST USE OF EARTH'S PRECIOUS AND LIMITED RESOURCES.

YOUR MEMBERSHIP IN THE ORDER IS SYMBOLIZED BY THE ACCEPTANCE OF AN "OBLIGATION" AND THE WEARING OF THE STAINLESS STEEL RING ON THE LITTLE FINGER OF THE WORKING HAND. THERE ARE NO MEETINGS OTHER THAN THIS CEREMONY, AND THERE ARE NO DUES.

AS I CALL YOUR NAMES, I WILL ASK EACH OF THE INDUCTEES TO PLEASE COME FORWARD WITH YOUR PROGRAM AND FORM A LINE TO THE SIDE OF THE TABLE. (OR APPROPRIATE LOCATION), WHERE YOU WILL TAKE THE OBLIGATION, AND SUBSEQUENTLY RECEIVE YOUR RING FROM (SPEAKER #3) WHO WILL PLACE THE RING ON THE LITTLE FINGER OF YOUR WORKING HAND.

LIST OF INDUCTEES: (CALL FORTH ONE AT A TIME)

1
2
3
4
5

WE ASK ALL CURRENT MEMBERS OF THE ORDER OF THE ENGINEER TO PLEASE STAND AND RENEW YOUR OBLIGATION. AT THIS TIME, PLEASE TURN TO THE OBLIGATION OF AN ENGINEER IN YOUR PROGRAM. IT IS WITH HUMILITY, AND THE NEED FOR DIVINE GUIDANCE THAT WE TAKE THIS

PLEDGE.

CANDIDATES, RAISE YOUR RIGHT HAND, AND FACE THE AUDIENCE, AS THIS IS A PLEDGE FROM YOU TO THE PUBLIC AND YOUR PEERS. ALL STANDING, RECITE WITH ME THE "OBLIGATION OF AN ENGINEER":

(SPEAKER #1 AND GROUP):

I AM AN ENGINEER. IN MY PROFESSION I TAKE DEEP PRIDE. TO IT I OWE SOLEMN OBLIGATIONS.

AS AN ENGINEER, I PLEDGE TO PRACTICE INTEGRITY AND FAIR DEALING, TOLERANCE AND RESPECT; AND TO UPHOLD DEVOTION TO THE STANDARDS AND THE DIGNITY OF MY PROFESSION, CONSCIOUS ALWAYS THAT MY SKILL CARRIES WITH IT THE OBLIGATION TO SERVE HUMANITY BY MAKING THE BEST USE OF THE EARTH'S PRECIOUS WEALTH.

AS AN ENGINEER, I SHALL PARTICIPATE IN NONE BUT HONEST ENTERPRISES. WHEN NEEDED, MY SKILL AND KNOWLEDGE SHALL BE GIVEN WITHOUT RESERVATION FOR THE PUBLIC GOOD. IN THE PERFORMANCE OF DUTY AND IN FIDELITY TO MY PROFESSION, I SHALL GIVE THE UTMOST.

AUDIENCE MAY BE SEATED, CANDIDATES PLEASE REMAIN STANDING.

(SPEAKER #3) WILL NOW PLACE THE RING ON THE LITTLE FINGER OF YOUR WORKING HAND.

LIST OF INDUCTEES: (WAIT FOR RING TO BE PLACED ON HAND BEFORE CALLING NEXT NAME)

1
2
3
4
5

CONGRATULATIONS! (LEAD APPLAUSE)

WE WILL NOW HAVE A FEW WORDS FROM ENGINEER (SPEAKER #2) ON PROFESSIONALISM & ETHICS...

(SPEAKER #2): PROFESSIONALISM & ETHICS

IT MEANS THAT I SHALL BE GUIDED BY THE HIGHEST STANDARDS OF HONESTY AND INTEGRITY AND I AT ALL TIMES STRIVE TO SERVE THE PUBLIC INTEREST. I SHALL NOT BE INFLUENCED BY CONFLICTING INTERESTS. I SHALL ACCEPT PERSONAL RESPONSIBILITY FOR MY PROFESSIONAL ACTIVITIES. I SHALL GIVE CREDIT FOR ENGINEERING WORK TO THOSE TO WHOM CREDIT IS DUE AND WILL RECOGNIZE THE PROPRIETARY INTERESTS OF OTHERS. IT IS ALSO A REMINDER OF THE VALUE SYSTEM I WAS BROUGHT UP WITH. IT IS THE REFRESHER OF THE GUIDING PRINCIPLES THAT I MUST ADHERE TO IN MY PROFESSIONAL LIFE.

TO CONCLUDE OUR CEREMONY, I CALL UPON ENGINEER (SPEAKER #1).

CONCLUDING REMARKS

(SPEAKER #1): AS WE CONCLUDE THIS ORDER OF THE ENGINEER CEREMONY, WE WELCOME EACH OF YOU TO THE PRIVILEGES AND THE OBLIGATION OF THE ORDER OF THE ENGINEER. THIS OBLIGATION MEANS MORE THAN THE RIGHT TO PRACTICE THE APPLICATION OF SCIENCE FOR THE BETTERMENT OF HUMANITY OR THE ENJOYMENT OF A GENEROUS FEE. THIS OBLIGATION MEANS WE ARE MORE THAN HIGHLY TRAINED TECHNICIANS. WE MUST BE ENGINEERING EDUCATORS, AS WELL, AND MUST LEARN TO APPLY OUR KNOWLEDGE AND TEACH OTHERS TO SEEK AND USE OUR SERVICES.

THIS RING IS A REMINDER OF OUR CALLING. IT SYMBOLIZES THE STRENGTH AND UNITY OF OUR PROFESSION. IN WHATEVER AVENUE OUR PROFESSION LEADS, IN CREATING A CLEANER ENVIRONMENT, DESIGNING A BETTER

BRIDGE, DEVISING A FINER PRODUCT, DEVELOPING A SAFER COMMUNITY,
THERE OUR TALENTS SHOULD BE APPLIED; NOT FOR AN HOUR, OR A DAY,
NOT FOR A YEAR, BUT FOR LIFE, ON LAND, ON THE SEA, IN THE AIR OR THE
VAST REACHES OF SPACE.

THIS CERTIFICATE IS YOUR CREED. IT BEARS YOUR NAME AND SIGNATURE.
IT IS YOUR PACT WITH YOUR PROFESSION. READ IT THOUGHTFULLY.
DISPLAY IT PUBLICLY. THIS IS YOUR RING. IN TIMES OF ANXIETY, LOOK ON IT
AND TAKE COURAGE. IN TIMES OF HONOR, REGARD IT WITH HUMILITY.
WEAR IT PROUDLY. GOD BLESS YOU, AND MAY GOD BLESS AMERICA.

THIS CONCLUDES THE CEREMONY – YOU MAY BE SEATED. (LEAD APPLAUSE)

**PROFESSIONAL SOCIETY-CENTRIC
ORDER OF THE ENGINEER CEREMONY SECTIONS
(WITH SUGGESTED SCRIPT – ALTERNATE 2)**

INTRODUCTION/WELCOME

(SPEAKER #1): GOOD MORNING/AFTERNOON/EVENING, AND WELCOME TO ALL. MY NAME IS _____ AND I WAS INDUCTED INTO THE ORDER OF THE ENGINEER BY (LINK #__, LINK NAME)

IF SPEAKER #1 IS AN ORDER OF THE ENGINEER GOVERNOR:

(SPEAKER #1): IT IS MY PRIVILEGE, ON BEHALF OF THE NATIONAL BOARD OF GOVERNORS OF THE ORDER OF THE ENGINEER, TO PRESIDE AND WELCOME YOU TO THIS ORDER OF THE ENGINEER CEREMONY.

IF SPEAKER #1 IS NOT AN ORDER OF THE ENGINEER GOVERNOR:

(SPEAKER #1): IT IS MY PRIVILEGE, ON BEHALF OF THE (PROFESSIONAL SOCIETY NAME), TO PRESIDE AND WELCOME YOU TO THIS ORDER OF THE ENGINEER CEREMONY.

OTHER MEMBERS OF THE ORDER WHO WILL BE ASSISTING IN CONDUCTING THIS CEREMONY ARE MY FELLOW COLLEAGUES, (SPEAKER #2) WHO WAS INDUCTED INTO THE ORDER BY (LINK #__, LINK NAME), AND (SPEAKER #3), WHO WAS INDUCTED BY (LINK #__, LINK NAME)

IF PRESENTING AN INVOCATION (OPTIONAL):

(SPEAKER #1): I WOULD LIKE TO NOW CALL UPON (INVOCATION SPEAKER NAME) TO PRESENT AN INVOCATION.

(INVOCATION SPEAKER): ETERNAL GOD, MASTER OF THIS STRANGE AND WONDERFUL UNIVERSE, WE ASK YOUR GUIDANCE IN THIS HOUR. WE

PRAISE YOU FOR THE RICHES OF CREATION AND FOR THE RESOURCES YOU HAVE PLACED IN OUR HANDS FOR US TO USE AS WE THINK BEST. WE ARE HUMBLLED BY THE SIZE OF THE TASK. LORD, GIVE US DEDICATION AND WISDOM TO MEET OUR OBLIGATION AS ENGINEERS. STRENGTHEN US WHEN THE LOAD SEEMS HEAVIER THAN WE CAN BEAR; LIFT US UP WHEN THINGS GO WRONG; AND HELP US NOT TO BE WEARY IN WELL DOING. UNDER DIVINE GUIDANCE, MAY WE UNDERTAKE SEEMINGLY IMPOSSIBLE PROJECTS, AND ACQUIT OURSELVES WITH HONOR. WE PRAY, TODAY, THAT THE OBLIGATION WE TAKE AND THE STAINLESS STEEL RING WE WEAR MAY BE EVIDENCES OF OUR VISION AND CALLING, AND THAT THIS WORLD MAY BE A HAPPIER AND BETTER PLACE BECAUSE WE CHOOSE TO MAKE IT SO, NOW AND FOR YEARS TO COME. **AMEN.**

(SPEAKER #1): THANK YOU. THIS MORNING/AFTERNOON/EVENING, WE WILL TELL YOU ABOUT THE HISTORY OF THE ORDER, THE PURPOSE OF THE ORDER, AND THE SIGNIFICANCE OF THE RING. YOU WILL PUBLICLY TAKE THE OBLIGATION OF THE ENGINEER, AND WE WILL CALL THE NEW INDUCTEES FORWARD AND PLACE THE STAINLESS STEEL RING ON THE LITTLE FINGER OF YOUR WORKING HAND. (SPEAKER #2) WILL NOW EXPLAIN THE HISTORY OF THE ORDER.

(SPEAKER #2): HISTORY OF THE ORDER

THIS CEREMONY PRESENTS AN OPPORTUNITY FOR US TO TAKE A PLEDGE AND TO RECALL THAT THE PROFESSIONAL PURPOSE OF ENGINEERING INVOLVES THE PURSUIT OF A LEARNED ART IN THE SPIRIT OF PUBLIC SERVICE. BY FOLLOWING THE ACCEPTANCE OF THE OBLIGATION, THE INDIVIDUAL ENGINEER REINFORCES SIMILAR EFFORTS OF HIS OR HER PEERS, REALIZING THAT IN UNITY THERE IS STRENGTH.

DECADES AGO, OUR ENGINEERING COUNTERPARTS IN CANADA HAD THIS SAME FEELING. THEY BELIEVED THAT A NEED EXISTED FOR THE INTRODUCTION OF A SPIRIT OF BROTHERHOOD AND COHESIVENESS AMONG

ENGINEERS. THE CANADIANS BELIEVED THAT A GOOD WAY TO ACHIEVE THIS PURPOSE WOULD BE TO INSTILL IN ENGINEERS A CONSCIOUSNESS OF BELONGING TO ONE ANOTHER, TO THEMSELVES AS INDIVIDUALS, AND TO THOSE WHOM THEY SERVED.

THUS, WHAT WAS DONE IN 1925 IN CANADA IS WHAT IS NOW KNOWN AS: "THE RITUAL OF THE CALLING OF AN ENGINEER." THE WORDS OF THE RITUAL WERE WRITTEN BY THE ENGLISH AUTHOR, RUDYARD KIPLING, WHO HAD MUCH DEPTH OF FEELING FOR ENGINEERS AS THE BUILDERS OF THINGS INTENDED TO BENEFIT MANKIND.

THE CANADIAN CEREMONY IS DIGNIFIED, IMPRESSIVE, AND INCLUDES THE PLACING OF A WROUGHT IRON RING ON THE SMALL FINGER OF THE INDIVIDUAL'S WORKING HAND, AND THEN HAVING THEM REPEAT IN CONCERT THE WORDS OF KIPLING. IT IS DIFFICULT TO VISUALIZE ANY BETTER SYMBOLISM THAN THAT OF A RING, WORN FOR ALL TO SEE, AND SAYING IN EFFECT, THAT HERE IS AN ENGINEER DEDICATED TO A PUBLICLY AVOWED OBLIGATION TO THE PROFESSION AND TO THOSE IT HAS SERVED. IN OHIO, THE IDEA OF SIMILAR MAXIMS TO THOSE WRITTEN BY KIPLING WERE WELL ESTABLISHED AND CORRESPONDENCE BEGAN IN OCTOBER 1953 BETWEEN THE CANADIAN WARDENS, RESPONSIBLE FOR THE ADMINISTRATION OF THE CALLING OF AN ENGINEER, AND OFFICERS OF THE OHIO SOCIETY OF PROFESSIONAL ENGINEERS, WITH A VIEW TO POSSIBLY EXTENDING THE CANADIAN CEREMONY TO THE UNITED STATES.

DUE TO COPYRIGHT AND OTHER CONFLICTING FACTORS, EXTENSION OF THE RITUAL INTO THIS COUNTRY WAS NOT POSSIBLE. DURING 1966, A GROUP OF ENGINEERS IN OHIO, WITH MEMBERS OF SEVERAL ENGINEERING ORGANIZATIONS, BEGAN TO PURSUE THE OBJECTIVE OF WHAT CAME TO BE CALLED THE "ORDER OF THE ENGINEER."

WHILE THE DELIBERATIONS OF THIS GROUP WERE IN PROGRESS, SENIORS OF FENN COLLEGE OF ENGINEERING AT CLEVELAND STATE UNIVERSITY,

COUNSELED BY DEAN BURL BUSH, DESIGNED AND HELD A RING CEREMONY AND RECEPTION ON JUNE 4, 1970. EACH PARTICIPANT SIGNED A CREED AND RECEIVED A PLAIN STAINLESS STEEL RING PLACED ON THE SMALL FINGER OF HIS OR HER WORKING HAND. ONE HUNDRED SEVENTY ENGINEERING SENIORS AND ENGINEERING FACULTY MEMBERS TOOK PART IN THIS FIRST CEREMONY. SINCE THEN, THE ORDER HAS GROWN TO INCLUDE TENS OF THOUSANDS OF MEMBERS INDUCTED AT LINKS (LOCAL CHAPTERS) ESTABLISHED IN NEARLY EVERY STATE IN THE UNION. ALTHOUGH PATTERNED AFTER THE CANADIAN CONCEPT, THE ORDER OF THE ENGINEER HAS DIFFERENCES THAT ARE DISTINCTIVELY ASSOCIATED WITH THE UNITED STATES OF AMERICA. WE ASK THAT YOU ACCEPT WITH PRIDE THE MEANING AND PURPOSE OF THE CEREMONY IN WHICH YOU ARE ABOUT TO PARTICIPATE: TO UPHOLD THE STANDARDS AND INTEGRITY OF THE ENGINEERING PROFESSION.

(SPEAKER #3) WILL NOW TELL US ABOUT THE PURPOSE OF THE ORDER...

(SPEAKER #3): PURPOSE OF THE ORDER

THE ORDER OF THE ENGINEER, TO WHICH YOU WILL SOON BELONG, IS AN INDEPENDENT ORGANIZATION. THE PURPOSE IS TO FOSTER A FEELING OF PRIDE IN AND DEDICATION TO THAT PROFESSION WHICH BINDS US TOGETHER.

YOU ARE ASKED TO ACCEPT WITH PRIDE THE MEANING OF THE CEREMONY TO WHICH YOU ARE ABOUT TO SUBSCRIBE. THE "OBLIGATION" SHOULD BE FREELY GIVEN AND THE RESPONSIBILITY GLADLY ACCEPTED. THE ORDER IS SYMBOLIZED BY THE ACCEPTANCE OF AN "OBLIGATION" AND THE WEARING OF A STAINLESS STEEL RING ON THE LITTLE FINGER OF THE WORKING HAND.

THE OBLIGATION IS THE FORMAL STATEMENT OF AN ENGINEER'S RESPONSIBILITIES TO THE PUBLIC AND TO THE PROFESSION. IT IS A CREED SIMILAR TO THE OATH ATTRIBUTED TO HIPPOCRATES THAT IS COMMONLY TAKEN BY MEDICAL GRADUATES AND WHICH SETS FORTH AN ETHICAL CODE.

THE OBLIGATION LIKEWISE CONTAINS PARTS OF THE CANON OF ETHICS OF MAJOR ENGINEERING SOCIETIES.

INITIATES, AS THEY VOLUNTARILY ACCEPT IT, PLEDGE TO UPHOLD THE STANDARDS AND DIGNITY OF THE ENGINEERING PROFESSION AND TO SERVE HUMANITY BY MAKING THE BEST USE OF EARTH'S PRECIOUS AND LIMITED RESOURCES. THE "OBLIGATION" IS A COMPOSITE OF SEVERAL CREEDS. IT EMPHASIZES THE FACT THAT WE, AS ENGINEERS, HAVE CERTAIN OBLIGATIONS. IT PROMOTES HONESTY AND INTEGRITY AND RECOGNIZES THAT TODAY'S ENGINEERS ARE DEPENDENT ON THEIR PREDECESSORS FOR THEIR SKILLS.

I NOW CALL UPON (SPEAKER #1) TO DISCUSS THE SIGNIFICANCE OF THE RING.

SIGNIFICANCE OF THE RING

(SPEAKER #1): I WILL NOW SHARE THE SIGNIFICANCE OF THE RING.

THE RING, A SYMBOL OF PRIDE, PRESTIGE, HONOR, AND PROFESSIONALISM AMONG ALL ENGINEERS IN THE UNITED STATES, ALSO SERVES AS A REMINDER OF OUR OBLIGATION TO SOCIETY.

THE SIGNIFICANCE OF WHAT YOU ARE ABOUT TO SAY AND DO MIGHT BE EXPRESSED THIS WAY:

- I AM AN ENGINEER
- I HAVE AN OBLIGATION TO MY PROFESSION
- MY DESIRE IS TO APPLY THE GOLDEN RULE, OUR CODE OF ETHICS, TO THE PRACTICE OF MY PROFESSION
- MY OBLIGATION IS THE YARDSTICK OF MY PROFESSIONALISM
- MY PROFESSIONALISM MEANS TO ME THAT I WILL NEVER ASK MYSELF THE QUESTION "HOW MUCH DO I GET OUT OF IT?" BUT RATHER, I WILL ASK "HOW MUCH CAN I GIVE?"

THE SYMBOL OF YOUR DESIRE TO SERVE THE PUBLIC IS THE ENGINEER'S RING. THE RING YOU WILL WEAR ON THE FIFTH FINGER OF THE WORKING HAND WILL SAY TO ALL WHO SEE IT — HERE IS AN ENGINEER, POSSESSED OF A PUBLICLY AVOWED DEDICATION TO THE PROFESSION AND THE PUBLIC THEY SERVE. IT IS OUR SYMBOL – WEAR IT FOR ALL TO SEE. THE RING IS A BADGE OF RECOGNITION WHICH WILL BECOME KNOWN TO ALL AS THE SIGN OF A LEARNED PROFESSIONAL PLEDGED TO MAKING THE BEST USE OF EARTH'S PRECIOUS AND LIMITED RESOURCES.

YOUR MEMBERSHIP IN THE ORDER IS SYMBOLIZED BY THE ACCEPTANCE OF AN "OBLIGATION" AND THE WEARING OF THE STAINLESS STEEL RING ON THE LITTLE FINGER OF THE WORKING HAND. THERE ARE NO MEETINGS OTHER THAN THIS CEREMONY, AND THERE ARE NO DUES.

I WILL NOW LEAD YOU THROUGH THE ACCEPTANCE OF YOUR OBLIGATION, YOUR RING AND YOUR INDUCTION INTO THE ORDER.

IN THE PRESENCE OF YOUR FELLOW ENGINEERS, EACH OF YOU WILL TAKE THE OBLIGATION AND SUBSEQUENTLY BE CALLED FORWARD TO RECEIVE YOUR CERTIFICATE AND RING. AT THIS TIME, WE ASK THAT ALL OF TODAY'S INDUCTEES PLEASE STAND TO TAKE THE OBLIGATION.

WE ALSO ASK ALL CURRENT MEMBERS OF THE ORDER OF THE ENGINEER TO PLEASE STAND AND RENEW YOUR OBLIGATION. AT THIS TIME, PLEASE TURN TO THE OBLIGATION OF AN ENGINEER IN YOUR PROGRAM. IT IS WITH HUMILITY AND THE NEED FOR DIVINE GUIDANCE THAT WE TAKE THIS PLEDGE.

THIS IS A PLEDGE FROM YOU TO THE PUBLIC AND YOUR PEERS. ALL STANDING, PLEASE RAISE YOUR RIGHT HAND AND RECITE WITH ME THE "OBLIGATION OF AN ENGINEER":

(SPEAKER #1 AND GROUP):

I AM AN ENGINEER. IN MY PROFESSION I TAKE DEEP PRIDE. TO IT I OWE SOLEMN OBLIGATIONS.

AS AN ENGINEER, I PLEDGE TO PRACTICE INTEGRITY AND FAIR DEALING, TOLERANCE AND RESPECT; AND TO UPHOLD DEVOTION TO THE STANDARDS AND THE DIGNITY OF MY PROFESSION, CONSCIOUS ALWAYS THAT MY SKILL CARRIES WITH IT THE OBLIGATION TO SERVE HUMANITY BY MAKING THE BEST USE OF THE EARTH'S PRECIOUS WEALTH.

AS AN ENGINEER, I SHALL PARTICIPATE IN NONE BUT HONEST ENTERPRISES. WHEN NEEDED, MY SKILL AND KNOWLEDGE SHALL BE GIVEN WITHOUT RESERVATION FOR THE PUBLIC GOOD. IN THE PERFORMANCE OF DUTY AND IN FIDELITY TO MY PROFESSION, I SHALL GIVE THE UTMOST.

WE ASK THAT EXISTING MEMBERS OF THE ORDER WHO RENEWED THEIR OBLIGATION BE SEATED, AND NEW CANDIDATES PLEASE REMAIN STANDING.

WE WILL NOW CALL THE NEW CANDIDATES FORWARD, AND (SPEAKER #3) WILL PLACE THE RING ON THE LITTLE FINGER OF YOUR WORKING HAND, YOU WILL THEN SIGN YOUR CERTIFICATE AND REMAIN AT THE FRONT OF THE ROOM AFTER RECEIVING YOUR RING AND CERTIFICATE.

LIST OF INDUCTEES: (WAIT FOR RING TO BE PLACED ON HAND BEFORE CALLING NEXT NAME)

1
2
3
4
5

CONGRATULATIONS! (LEAD APPLAUSE)

CONGRATULATIONS ON YOUR INDUCTION INTO THE ORDER OF THE ENGINEER. NOW PLEASE RETURN TO YOUR SEATS AND I WILL INVITE (SPEAKER #2) TO SAY A FEW WORDS ABOUT RESPONSIBIITY AND ETHICS.

(SPEAKER #2): PROFESSIONALISM & ETHICS

IT MEANS THAT I SHALL BE GUIDED BY THE HIGHEST STANDARDS OF HONESTY AND INTEGRITY AND I AT ALL TIMES STRIVE TO SERVE THE PUBLIC INTEREST. I SHALL NOT BE INFLUENCED BY CONFLICTING INTERESTS. I SHALL ACCEPT PERSONAL RESPONSIBILITY FOR MY PROFESSIONAL ACTIVITIES. I SHALL GIVE CREDIT FOR ENGINEERING WORK TO THOSE TO WHOM CREDIT IS DUE AND WILL RECOGNIZE THE PROPRIETARY INTERESTS OF OTHERS. IT IS ALSO A REMINDER OF THE VALUE SYSTEM I WAS BROUGHT UP WITH. IT IS THE REFRESHER OF THE GUIDING PRINCIPLES THAT I MUST ADHERE TO IN MY PROFESSIONAL LIFE.

TO CONCLUDE OUR CEREMONY, I CALL UPON ENGINEER (SPEAKER #1).

CONCLUDING REMARKS

(SPEAKER #1): AS WE CONCLUDE THIS ORDER OF THE ENGINEER CEREMONY, WE WELCOME EACH OF YOU TO THE PRIVILEGES AND THE OBLIGATION OF THE ORDER OF THE ENGINEER. THIS OBLIGATION MEANS MORE THAN THE RIGHT TO PRACTICE THE APPLICATION OF SCIENCE FOR THE BETTERMENT OF HUMANITY OR THE ENJOYMENT OF A GENEROUS FEE. THIS OBLIGATION MEANS WE ARE MORE THAN HIGHLY TRAINED TECHNICIANS. WE MUST BE ENGINEERING EDUCATORS, AS WELL, AND MUST LEARN TO APPLY OUR KNOWLEDGE AND TEACH OTHERS TO SEEK AND USE OUR SERVICES.

THIS RING IS A REMINDER OF OUR CALLING. IT SYMBOLIZES THE STRENGTH AND UNITY OF OUR PROFESSION. IN WHATEVER AVENUE OUR PROFESSION LEADS, IN CREATING A CLEANER ENVIRONMENT, DESIGNING A BETTER

BRIDGE, DEVISING A FINER PRODUCT, DEVELOPING A SAFER COMMUNITY,
THERE OUR TALENTS SHOULD BE APPLIED; NOT FOR AN HOUR, OR A DAY,
NOT FOR A YEAR, BUT FOR LIFE, ON LAND, ON THE SEA, IN THE AIR OR THE
VAST REACHES OF SPACE.

THIS CERTIFICATE IS YOUR CREED. IT BEARS YOUR NAME AND SIGNATURE.
IT IS YOUR PACT WITH YOUR PROFESSION. READ IT THOUGHTFULLY.
DISPLAY IT PUBLICLY. THIS IS YOUR RING. IN TIMES OF ANXIETY, LOOK ON IT
AND TAKE COURAGE. IN TIMES OF HONOR, REGARD IT WITH HUMILITY.
WEAR IT PROUDLY.

I ASK THE AUDIENCE TO JOIN ME IN CONGRATULATING THE NEWEST
MEMBERS OF THE ORDER OF THE ENGINEER (LEAD APPLAUSE).

**THIS CONCLUDES THE ORDER OF THE ENGINEER CEREMONY. THANK YOU
ALL FOR PARTICIPATING.**

APPENDICES

- A. The Obligation of an Engineer
- B. Supplemental Information – “The Order of the Engineer”; An article from *The Professional Engineer*, November/December, 1996, by Kenneth K. Humphreys, P.E., FSNSPE, FPENC.
- C. Sample Script - The Order of the Engineer Ring Ceremony
- D. Sample Programs & Covers
- E. Order of the Engineer Ceremony Materials Order Form
- F. Order of the Engineer Link Update Form
- G. Order of the Engineer Ring Size Form
- H. Application for Charter
- I. Ring Replacement Order Form
- J. Sample Certificate
- K. Example of Possible Room Layout for Ceremony
- L. Ceremonial Ring for the Order of the Engineer



THE OBLIGATION OF AN ENGINEER

(Reproduce a sufficient number of copies for each candidate)

I AM AN ENGINEER. IN MY PROFESSION I TAKE DEEP PRIDE. TO IT I OWE SOLEMN OBLIGATIONS.

AS AN ENGINEER, I PLEDGE TO PRACTICE INTEGRITY AND FAIR DEALING, TOLERANCE AND RESPECT; AND TO UPHOLD DEVOTION TO THE STANDARDS AND THE DIGNITY OF MY PROFESSION, CONSCIOUS ALWAYS THAT MY SKILL CARRIES WITH IT THE OBLIGATION TO SERVE HUMANITY BY MAKING THE BEST USE OF THE EARTH'S PRECIOUS WEALTH.

AS AN ENGINEER, I SHALL PARTICIPATE IN NONE BUT HONEST ENTERPRISES. WHEN NEEDED, MY SKILL AND KNOWLEDGE SHALL BE GIVEN WITHOUT RESERVATION FOR THE PUBLIC GOOD. IN THE PERFORMANCE OF DUTY AND IN FIDELITY TO MY PROFESSION, I SHALL GIVE MY UTMOST.

SUPPLEMENTAL INFORMATION

(This information may be useful in promoting participation in the ceremony and/or for publicity and press releases)

1. The Origins of the Order of the Engineer

That iron ring! What is it? You may have seen an engineer wearing a plain ring on his or her little finger and wondered what it was. It looks like a simple wedding band and in a manner of speaking it is. It is the symbol of an engineer who is "married" to the profession. It is the outward sign that the engineer is a member of the Order of the Engineer.

What is the Order of the Engineer? Why do engineers wear the ring? How and where did the custom start? Its roots stem from the Canadian's *Ritual of the Calling of an Engineer*. The Ritual of the Calling of an Engineer has a history dating back to 1922, when seven past-presidents of the Engineering Institute of Canada attended a meeting in Montreal with other engineers. One of the speakers was Professor H.E.T. Haultain, a mining engineering professor at the University of Toronto. He felt that an organization was needed to bind all members of the engineering profession in Canada more closely together. He felt that an obligation or statement of ethics to which a young graduate in engineering could subscribe should be developed, envisioning a ceremony similar to that of physicians when they take the Hippocratic Oath upon entering their profession. The seven past-presidents of the Engineering Institute of Canada were very receptive to this idea.

Prof. Haultain wrote to Rudyard Kipling, who had made reference to the work of engineers in some of his poems and writings. He asked Kipling for his assistance in developing a suitably dignified obligation and ceremony for its undertaking. Kipling was very enthusiastic in his response, and shortly produced both an obligation and a ceremony formally entitled "The Ritual of the Calling of an Engineer" in which each engineer accepts an obligation to practice in a professional and competent manner and to "honourably guard" the reputation of the profession. The engineers, upon accepting the obligation, are presented with a ring to wear on the small finger of the working hand.

Years earlier, in 1907, a wrought iron bridge was being built over the St. Lawrence River at Quebec City in Canada. At the time, this bridge was to be the world's largest single cantilevered span. Unfortunately, the bridge proved to be under designed and it collapsed into the St. Lawrence killing 76 construction workers. The engineers had deviated from accepted procedures, tried to save some time and effort, under-calculated the weight of the bridge, and under-designed key structural members.

The first Ritual of the Calling of an Engineer ring ceremony was held at the University of Toronto in 1925. The circular shape of the ring itself is to symbolize the continuity of the profession and it has become the virtual universal symbol of the profession in Canada where over 99% of all engineers wear the ring. The current day Canadian

ceremony's sole but poignant commemoration to the Quebec Bridge disaster is the permanent attachment of a rivet from the fallen bridge to many of the continuous chains used in the ceremonies across Canada. Chains are held in the Obligants' left hand while raising the right hand to swear the Oath, with the chain attached to an old and used anvil, grasped by the Supervising Engineer during the recital of the Oath by all Obligants.

In Ohio in 1953, correspondence began between members of the Ohio Society of Professional Engineers and the Canadian Wardens, who are responsible for the Canadian ceremony, with a view to possibly extend the Canadian ceremony to the United States. Due to copyright and other conflicting factors, extension of the ritual to this country was not possible.

In 1966, a group of Ohio engineers proposed a similar ceremony for US engineers using a stainless steel ring. Dean Burl Bush of the College of Engineering at Cleveland State University and his students seized upon the idea, designed a ring ceremony, and on June 4, 1970 inducted one hundred and seventy engineering seniors and engineering faculty members into the "Order of the Engineer." Each participant signed a creed expressing dedication to the ethics and professionalism of engineering. Each of those inductees received a plain stainless steel ring placed on the small finger of his or her working hand. Thus began the custom of the engineer's ring in the United States, a custom which has now spread to every state and which has become an integral part of NSPE and State Society meetings, as well as those of other engineering societies. The first North Carolina ceremony was held in May 1975, and the ceremony is now a regular part of PENC meetings and chapter meetings statewide.

The ring is the sign of your profession and symbolizes your obligation and promise to practice your profession in an ethical and competent manner. If you don't already wear the ring, take the first opportunity you have to join the Order of the Engineer and take on this visible symbol of professionalism. Unlike other organizations, the Order has no meetings other than the ceremony of induction, there are no dues, and the only monetary cost is the induction fee of \$15.00. It is your privilege to participate in the ceremony and ritual.

Sources:

- An article from *The Professional Engineer* entitled "***The Order of the Engineer***" by *Kenneth K. Humphreys, PE, FNSPE FPENC*, Nov/Dec 1996.
- The Corporation of the Seven Wardens.

2. The Fundamental Canons of the NSPE Code of Ethics for Engineers

Preamble

Engineering is an important and learned profession. As members of this profession, engineers are expected to exhibit the highest standards of honesty and integrity. Engineering has a direct and vital impact on the quality of life for all people. Accordingly, the services provided by engineers require honesty, impartiality, fairness and equity, and must be dedicated to the protection of the public health, safety, and welfare. Engineers must perform under a standard of professional behavior that requires adherence to the highest principles of ethical conduct.

Fundamental Canons

Engineers, in the fulfillment of their professional duties, shall:

1. Hold paramount the safety, health and welfare of the public.
2. Perform services only in areas of their competence.
3. Issue public statements only in an objective and truthful manner.
4. Act for each employer or client as faithful agents or trustees.
5. Avoid deceptive acts.
6. Conduct themselves honorably, responsibly, ethically, and lawfully so as to enhance the honor, reputation, and usefulness of the profession.

3. The Engineer's Creed

As a Professional Engineer, I dedicate my professional knowledge and skill to the advancement and betterment of human welfare.

I pledge:

To give the utmost of performance;
To participate in none but honest enterprise;
To live and work according to the laws of man and the highest standards of professional conduct;
To place service before profit, the honor and standing of the profession before personal advantage, and the public welfare above all other considerations.
In humility and with need for Divine Guidance, I make this pledge.

(Adopted by National Society of Professional Engineers, June 1954)



The Order of the Engineer Ring Ceremony

Alternative Sample Script

- **Welcome** (Speaker #1)

Remarks Welcoming

- Seniors and their Families
- Special Inductees and their Families
- Alumni
- Practicing Engineers
- Faculty
- Guests

- **Introductions** (Speaker #2)

- **History of the Order** (Speaker #3)

Decades ago, our engineering counterparts in Canada found the need for the introduction of a spirit of community and cohesiveness among engineers. The Canadians believed that a good way to go about achieving this would be to instill in engineers a consciousness of belonging to one another, to themselves as individuals, and to those they serve.

The result of this need for community resulted in the Canadian “Ritual of the Calling of an Engineer.” The words of the ritual were written by the British author, Rudyard Kipling. The ritual also included the placing of a wrought iron ring on the small finger of the working hand.

Maxims similar to those of Kipling took hold in Ohio, and correspondence began between members of the Canadian Calling and the then officers of the Ohio Society of Professional Engineers, notably Lloyd Chacey, Homer Borton, and Brooks Earnest – with a view toward extending the Canadian ceremony to the United States. Due to legal restrictions, this was not possible. However, at the invitation of the Canadian wardens, Homer Borton and Brooks Earnest received their first rings in Canada.

During 1966, a group of U.S. engineers began to pursue the establishment of what was then known in Ohio as “The Order of the Engineer.” While this group deliberated, seniors at the Fenn College of Engineering at Cleveland State University, counseled by Dean Burl Bush, designed and held the first ring ceremony and reception on June 4, 1970. About 170 engineering seniors and faculty members participated in the ceremony, during which each participant signed a creed and received a stainless steel ring placed on the small finger of

the working hand. A second ceremony was held in Akron, Ohio in February 1971, which included seniors at the University of Akron and practicing engineers.

Since then, the Order has grown to include tens of thousands of members inducted at Links (local chapters) established in nearly every state in the Union. Although patterned after the Canadian concept, The Order of the Engineer has differences that are distinctively associated with the United States of America. We ask that you accept with pride the meaning and purpose of the ceremony in which you are about to participate: to uphold the standards and integrity of the engineering profession.

I would now like to ask Speaker #4 to describe to you the significance of the Obligation and the Engineer's Ring.

- **Significance of the Obligation and the Ring (Speaker #4)**

Candidates for the Order, guests and friends, the Order of the Engineer, to which you will soon belong, is an independent organization. Its purpose is to foster a feeling of pride in and dedication to that profession which binds us together.

The Order is symbolized by the acceptance of an "Obligation" and the wearing of a stainless steel ring on the little finger of the working hand. There are no meetings other than this ceremony, and there are no dues.

The "Obligation" to which you will soon subscribe is a composite of several creeds. It emphasizes the fact that we, as engineers, have certain obligations. It promotes honesty and integrity, and recognizes that today's engineers are dependent upon their predecessors for the skills they have learned.

The significance of what you are about to say and do might be expressed this way:

- I am an engineer
- I have an obligation to my profession
- My desire is to apply the Golden Rule, our code of ethics, to the practice of my profession
- My obligation is the yardstick of my professionalism
- My professionalism means to me that I will never again ask myself the question, "How much do I get out of it?" But rather that I will ask, "How much can I give?"

The symbol of the desire to be a giver is the Engineer's ring. The ring says to all who see it, "Here is an engineer, possessed of a publicly avowed dedication to his profession and the public it serves."

I now ask Speaker #5 to call the names of the assembled engineers to receive their Rings and Obligation Certificates.

- **Acceptance of the Obligation of an Engineer (Speaker #5)**

Will the candidates please come forward and face the audience (*Candidates come forward and approach the stage accordingly*). Please direct your attention to the back page of the program. Let's read in unison, the Obligation.

Instructions - Read the Obligation statement (on the program) with the Candidates.

OBLIGATION OF THE ENGINEER

I AM AN ENGINEER. IN MY PROFESSION I TAKE DEEP PRIDE. TO IT I OWE SOLEMN OBLIGATIONS.

AS AN ENGINEER, I PLEDGE TO PRACTICE INTEGRITY AND FAIR DEALING, TOLERANCE AND RESPECT; AND TO UPHOLD DEVOTION TO THE STANDARDS AND THE DIGNITY OF MY PROFESSION, CONSCIOUS ALWAYS THAT MY SKILL CARRIES WITH IT THE OBLIGATION TO SERVE HUMANITY BY MAKING THE BEST USE OF THE EARTH'S PRECIOUS WEALTH.

AS AN ENGINEER, I SHALL PARTICIPATE IN NONE BUT HONEST ENTERPRISES. WHEN NEEDED, MY SKILL AND KNOWLEDGE SHALL BE GIVEN WITHOUT RESERVATION FOR THE PUBLIC GOOD. IN THE PERFORMANCE OF DUTY AND IN FIDELITY TO MY PROFESSION, I SHALL GIVE MY UTMOST.

- **Presentation of Obligation and Ring**

As I call your name, please approach Speaker #6, who will place the ring on your working hand and hand you your Obligation Certificate

Instructions - The Candidates' names are called. The ring is placed on the Candidate's working hand, and the Obligation Certificate is presented to them. List attached.

- *Read the names of the Special Inductees and Recognition Statements*
- *Read the names of Students/Faculty*

The Candidates will now sign their Obligation Certificates.

- **Closing Remarks** (Speaker #7)

The certificate is your creed. It bears your name and signature. It is your pact with your profession. Display it publicly.

The ring is a reminder of our calling. Wear your ring proudly. You are an engineer.

- **Reception** (Speaker #8)

This completes The Order of the Engineer Ring Ceremony. Everyone is invited to attend an informal reception for the new members of The Order of the Engineer.



Appendix D

SAMPLE ANNOUNCEMENTS, PROGRAMS & COVERS

Announcement Example 1:

Sample Ceremony Announcement for a University Setting

Seniors and Graduate Students:

Do you think ethics are important?
Do you want to show future employers you value ethics?

Join the...

Order of the Engineer

The national engineering ethics organization

\$10 to join but **no meetings or dues**

Take the oath on April 13th at 1:00 PM

Benefits of joining the Order:

1. Reflect on ethics as you start your career
2. Receive a steel ring and certificate
3. Network with other members
4. Add it to your résumé

Presented by RPI Tau Beta Pi

Questions? Email straus3@rpi.edu



Announcement Example 2:

Sample Ceremony Announcement for a Professional Society Setting



ORDER OF THE ENGINEER CEREMONY

Presented by the

**Kansas Society of Professional
Engineers**

June 7, 2018

9:15 a.m.

Hilton Garden Inn, Manhattan, Kansas

The Order of the Engineer is an independent organization whose purpose is to foster a feeling of pride in and dedication to the engineering profession. During the ceremony, each inductee takes a solemn obligation to uphold devotion to the standards and the dignity of the engineering profession. The obligation is a creed similar to the oath attributed to Hippocrates that is commonly taken by medical graduates and which sets forth an ethical code. The obligation likewise contains parts of the canon of ethics of major engineering societies. The Order promotes honesty and integrity, and recognizes that today's engineers are dependent on their predecessors for their skills. A stainless steel ring is worn on the little finger of the working hand to symbolize acceptance of the obligation.

KSPE/NSPE members who wear the ring help raise awareness of the concepts of licensure and professionalism. This awareness is extended to recent engineering graduates, to non-KSPE/NSPE members, and to the general public. Promoting the Order of the Engineer provides an opportunity for NSPE and its state partners to grow our membership. A strong membership base helps promote and protect the engineering license. You are invited to join in this important promotion of the licensed engineer. Please sign up to take the oath to serve humanity by making the best use of earth's precious wealth!

Name: _____ Major: _____

Please print your name as you would like it to appear on your certificate

School: _____ Year Graduated: _____

Permanent Address: _____

E-mail Address: _____

Ring Size (last finger on working hand): _____

Signature: _____ Date: _____

There is a \$20 fee to participate.

Return this form with your KSPE Conference Registration form and fees by May 10 to:

**KSPE
825 S. Kansas Avenue, Suite 500
Topeka, Kansas 66612
Fax: 785.233.2206
www.kansasengineer.org**

OBLIGATION OF AN ENGINEER

(New members read aloud)

I am an Engineer. In my profession I take deep pride. To it I owe solemn obligations.

As an Engineer, I pledge to practice integrity and fair dealing, tolerance and respect; and to uphold devotion to the standards and the dignity of my profession, conscious always that my skill carries with it the obligation to serve humanity by making the best use of the Earth's precious wealth.

As an Engineer, I shall participate in none but honest enterprises. When needed, my skill and knowledge shall be given without reservation for the public good. In the performance of duty and in fidelity to my profession, I shall give my utmost.

In the presence of your fellow engineers please sign your name on the Obligation of the Engineer.



The image shows the front cover of a booklet. The background is dark with a subtle, repeating pattern of the words "ORDER OF THE ENGINEER" in a light color. At the top, the title "THE ORDER OF THE ENGINEER" is written in a large, white, serif font. Below the title is a close-up photograph of a simple, silver-colored metal ring. In the lower half of the cover, the text "INSERT CEREMONY INFORMATION (UNIVERSITY, LOCATION, DATE, TIME)" is printed in a white, sans-serif font. At the very bottom, a horizontal line of small, white, all-caps text lists the core values: "INTEGRITY TOLERANCE RESPECT DEVOTION HONESTY DIGNITY".

The Order of the Engineer

The Order of the Engineer is a national organization whose purpose is to foster a spirit of pride, individual integrity, and responsibility in the engineering profession. It promotes ethics and professionalism in the practice of engineering and bridges the gap between education and practice.

Membership is voluntary and open to seniors and graduate students in EAC of ABET-accredited engineering programs, graduate students enrolled in other engineering programs housed in departments that administer EAC of ABET - accredited undergraduate programs, graduates of EAC of ABET-accredited engineering programs, licensed professional engineers, members of the Canadian Calling, and special individuals.

As part of this ceremony, inductees take a solemn obligation to themselves to “uphold devotion to the standards and dignity of the engineering profession”.

Each inductee who accepts the obligation receives a stainless steel ring. The ring is to be worn on the fifth finger of the working hand. Inductees are encouraged to wear the ring and to display the signed obligation certificate as visible reminders of the publicly accepted obligation as a contract with themselves.



◆INTEGRITY TOLERANCE RESPECT DEVOTION HONESTY DIGNITY◆

The Order of the Engineer

Engineers' Ring Ceremony



PROGRAM

- Welcome
- History of the Order of the Engineer
- Significance of the Order
- Significance of the Ring
- Presentation of the Obligation and the Ring
- Acceptance of the Obligation of an Engineer
- Concluding Remarks
- Adjournment

Please join us for an informal reception at the conclusion of the program.



◆INTEGRITY TOLERANCE RESPECT DEVOTION HONESTY DIGNITY◆



History of the Order of the Engineer

The Ritual of the Calling of An Engineer was begun in 1925, when our engineering counterparts in Canada recognized the special obligation of engineers to one another, to the profession, and to the public they served. In the Canadian Ceremony, engineers inducted into the Order received a faceted ring during a private ceremony and accepted the engineer's oath based on writings by Rudyard Kipling.

Based on the model of the Canadian Ritual of the Calling, the Order of the Engineer was established in the United States in 1970 with the first Ring Ceremony being conducted by students at Cleveland State University's Fenn College of Engineering. In 1972, the Order of the Engineer was incorporated in Ohio, and tacit approval was obtained from the Canadian Wardens. The Order's national office remained in Ohio until 1987 when it was relocated to the United Engineering Center in New York City. The Order now has its office in Scottsdale, AZ.

The Order is governed at the national level by a National Board of Governors, composed of as many as 21 engineers who serve three-year terms. The National Board establishes policy, directs the national office, and charters local "Links" governed by local boards of governors. Such "Links" are granted the right to conduct Ring Ceremonies. The University of New Hampshire became a Link for the Order of the Engineer in 1994. Since then, UNH has hosted an annual Order of the Engineer ceremony. In the most recent years, the ceremony has been held on the third Thursday of April, corresponding with the annual NHASCE April meeting held here on the UNH campus.

There is no formal connection between the Order of the Engineer and other national engineering organizations; it is independent. However, the Order recognizes ABET's accreditation of engineering programs as a primary measurement of educational credentials for an engineer in the United States. In addition, Links of the Order have been chartered to various local components of Tau Beta Pi, NSPE, ASCE, and many other engineering societies.

Order of the Engineer Candidates

Date, 20xx

Enter Candidate Names

Special Thanks

Mr. Name	American Society of Civil Engineers
Mr. Name	ASCE – State
Mr. Name	ASCE –State
Dr. Name	University of ????
Dr. Name	University of ????
Dr. Name	University of ????



Ceremony

Xxxxx Annual Conference
Location, State
Time ?? Date
??

Hosted by the
?????

NSPE World Headquarters, Link 220

Conducted By

OE Presenter 1, P.E.
OE Presenter 2, P.E.
OE Presenter 3, P.E.



Order of the Engineer

Program

Call to Order and Introduction – Speaker

History and Purpose of the Order – Speaker

Significance of the Ring – Speaker

**Administration of the Obligation of the Order of the Engineer –
Speaker**

Ring Ceremony – All

Conclusion - Speaker



The Order of the Engineer is a solemn obligation to oneself to uphold devotion to the standards and the dignity of the engineering profession. It is an obligation to turn to practical use the principles of science and the means of technology to serve humanity by making the best use of earth's precious wealth.

Obligation of an Engineer

I am an Engineer. In my profession I take deep pride. To it I owe solemn obligations.

As an Engineer, I pledge to practice integrity and fair dealing, tolerance and respect; and to uphold devotion to the standards and the dignity of my profession, conscious always that my skill carries with it the obligation to serve humanity by making the best use of the Earth's precious wealth.

As an Engineer, I shall participate in none but honest enterprises. When needed, my skill and knowledge shall be given without reservation for the public good. In the performance of duty and in fidelity to my profession, I shall give my utmost.

* Inductees and members will read aloud and profess



Appendix E

ORDER OF THE ENGINEER
CEREMONY MATERIALS ORDER FORM

Order of the Engineer ORDER FORM



Order of the Engineer, Inc.
 ATTN: Paula Ostaff
 P.O. Box 25473
 Scottsdale, AZ 85255-0107
 Tel: (866) ENG-RINGS or
 (866) 364-7464
 Fax: (480) 585-6418
 E-mail: orderofeng@gmail.com
 Web: www.order-of-the-engineer.org

Link No. _____ Name: _____
 Organization: _____
 Address: _____
 City: _____ State: _____ Zip Code: _____
 Telephone: _____ FAX: _____
 E-Mail: _____

Date of Order _____

Date of Ceremony _____

Purchase Order # _____

Credit Card # _____

Exp. Date & CCID _____

**ONLY PURCHASE ORDERS ARE BILLED
 MAKE CHECKS PAYABLE TO THE ORDER OF THE ENGINEER**

ITEM	QTY	PRICE	AMOUNT
MEMBERSHIP & RINGS - Indicate required sizes on Ring Size Order Form - Price includes certificate and Card - Price includes ring at cost		\$10.00	
RING REPLACEMENT (Please include ring size) - Handling & Shipping Included		\$15.00	
OBLIGATION CERTIFICATE & POCKET CARD - One Set included with each ring otherwise \$0.25 per set		\$0.25	
PROGRAM COVER		\$0.36	
TRI-FOLD PAMPHLET " INTEGRITY, TOLERANCE, RESPECT, DEVOTION, HONESTY, DIGNITY"		\$1.25	
METAL RING SIZER		\$15.00	
LARGE CEREMONIAL RING		\$125.00	
PODIUM BANNER		\$30.00	
OE BOOK "THE OBLIGATION"		\$28.00	
SHIPPING - PRIORITY MAIL		\$7.50	
SHIPPING - FEDEX		\$40.00	
TOTAL:			

"Upholding Devotion to the Standards and Dignity of the Engineering Profession"
 P.O. Box 25473, Scottsdale, AZ 85255-0107 * Telephone (866) 364-7464 * Fax (480) 585-6418
 E-Mail: orderofeng@gmail.com



Appendix F

ORDER OF THE ENGINEER LINK INFORMATION FORM



LINK INFORMATION FORM

Submit each January OR whenever information changes

To: ORDER OF THE ENGINEER, INC.
ATTN: Paula Ostaff
P.O. Box 25473
Scottsdale, AZ 85255-0107

Link No. _____ Date _____

This link is associated with/sponsored by the following engineering organization:

Link Name: _____

Link Contact Person: _____

Title: _____

Address: _____

Phone: (Link Number) _____

Fax: _____ E-mail: _____

Alternate Contact: (if applicable) _____

Other Information/ Link news:

Submitted By: _____

Phone: _____ E-mail _____



Appendix G

ORDER OF THE ENGINEER RING SIZE ORDER FORM



Ring Size Order Form
Listing of Ring Sizes Desired

Quantity	Ring Size	Quantity	Ring Size
	1 ½		7 ¾
	2		8
	2 ¼		8 ¼
	2 ½		8 ½
	2 ¾		8 ¾
	3		9
	3 ¼		9 ¼
	3 ½		9 ½
	3 ¾		9 ¾
	4		10
	4 ¼		10 ¼
	4 ½		10 ½
	4 ¾		10 ¾
	5		11
	5 ¼		11 ¼
	5 ½		11 ½
	5 ¾		11 ¾
	6		12
	6 ¼		12 ¼
	6 ½		12 ½
	6 ¾		12 ¾
	7		13
	7 ¼		13 ½
	7 ½		



Appendix H

ORDER OF THE ENGINEER APPLICATION FOR CHARTER



THE ORDER OF THE ENGINEER, INC.

Application for Charter

What do you want your Link to be called? _____

We hereby apply for a charter for the _____

Link of "THE ORDER OF THE ENGINEER".

Our first Engineer's Ring Ceremony will be conducted on (date) _____ at

The three undersigned wearers of the Engineers Ring will participate in the first ceremony

1. _____

2. _____

3. _____

The charter will be displayed at _____

(building name and complete address)

Send Charter to:

Name: _____

Street address: _____

City: _____ State: _____ Zip: _____

Telephone: _____ Fax: _____ E-mail: _____

To complete application, attach list of inductees and a remittance of \$10 per inductee and mail completed application to:

ORDER OF THE ENGINEER, INC.

ATTN: Paula Ostaff

P.O. Box 25473

Scottsdale, AZ 85255-0107



ORDER OF THE ENGINEER
RING REPLACEMENT ORDER FORM

Order of the Engineer
RING REPLACEMENT FORM



Order of the Engineer, Inc.
ATTN: Paula Ostaff
P.O. Box 25473
Scottsdale, AZ 85255-0107
Tel: (866) ENG-RINGS or
(866) 364-7464
Fax: (480) 585-6418
E-mail: orderofeng@gmail.com
Web: www.order-of-the-engineer.org

Name: _____
Address: _____
City: _____ State: _____ Zip Code: _____
Telephone: _____ Fax: _____
E-Mail: _____

University or Association where Inducted:

Year Inducted: _____

CHECKS OR CREDIT CARDS WILL BE ACCEPTED

Credit Card # _____

Exp. Date & CCID _____

MAKE CHECKS PAYABLE TO THE ORDER OF THE ENGINEER

ITEM	QTY	PRICE	AMOUNT
RING REPLACEMENT (Please include ring size) - Handling & Shipping Included		\$15.00	
POCKET CARD - One Set included with each ring otherwise \$0.25 per set		\$0.25	
PROGRAM COVER		\$0.36	
TRI-FOLD PAMPHLET "INTEGRITY, TOLERANCE, RESPECT, DEVOTION, HONESTY, DIGNITY"		\$1.25	
SHIPPING (Forms Only)		\$5.00	
SHIPPING - FEDEX		\$40.00	
TOTAL:			



ORDER OF THE ENGINEER SAMPLE CERTIFICATE

It is recommended that Links order certificates directly from the Order of the Engineering to ensure high resolution and quality

OBLIGATION OF AN ENGINEER

I am an Engineer. In my profession I take deep pride. To it I owe solemn obligations.

As an Engineer, I

pledge to practice integrity and fair dealing, tolerance and respect; and to uphold devotion to the standards and the dignity of my profession, conscious always that my skill carries with it the obligation to serve humanity by making the best use of the Earth's precious wealth.

As an Engineer, I shall participate in none but honest enterprises. When needed, my skill and knowledge shall be given without reservation for the public good. In the performance of duty and in fidelity to my profession, I shall give my utmost.



Signature

Date

Location



SUGGESTED CEREMONY ROOM LAYOUTS

Following are suggested examples of room arrangements and remarks which may be helpful in defining your link's ring ceremony.

Some ceremonies utilize a "ceremonial ring" whereby the graduates place their little finger through the ceremonial ring before signing the Obligation. Specifications are given for construction of a ceremonial ring, followed by a picture of a ceremonial ring.

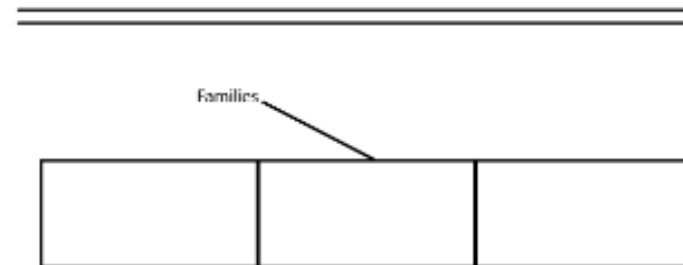
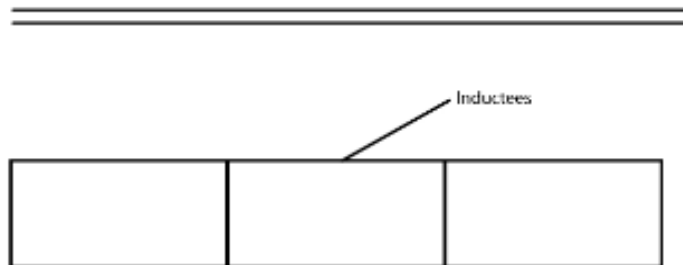
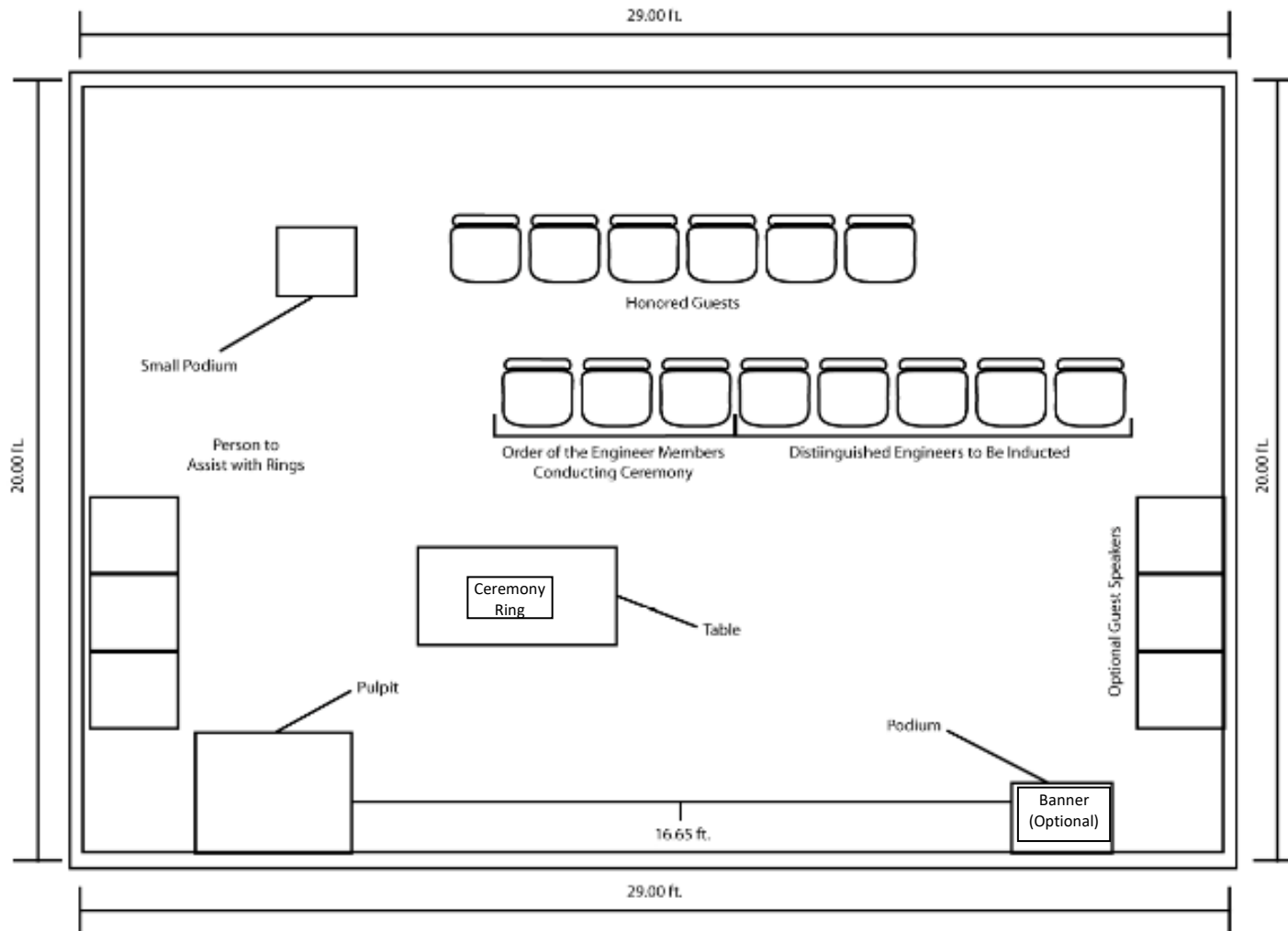

EXAMPLE OF POSSIBLE ROOM LAYOUT FOR CEREMONY

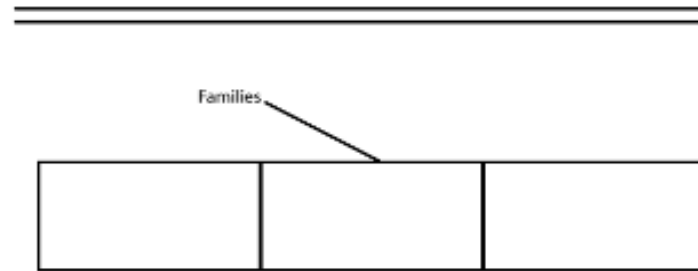
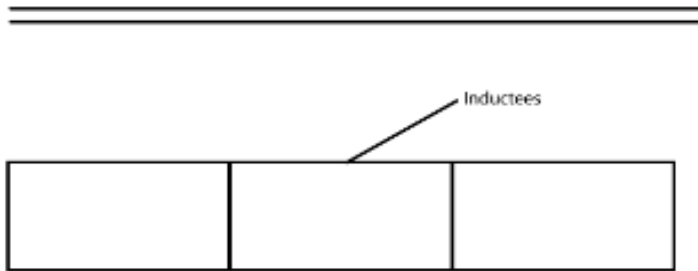
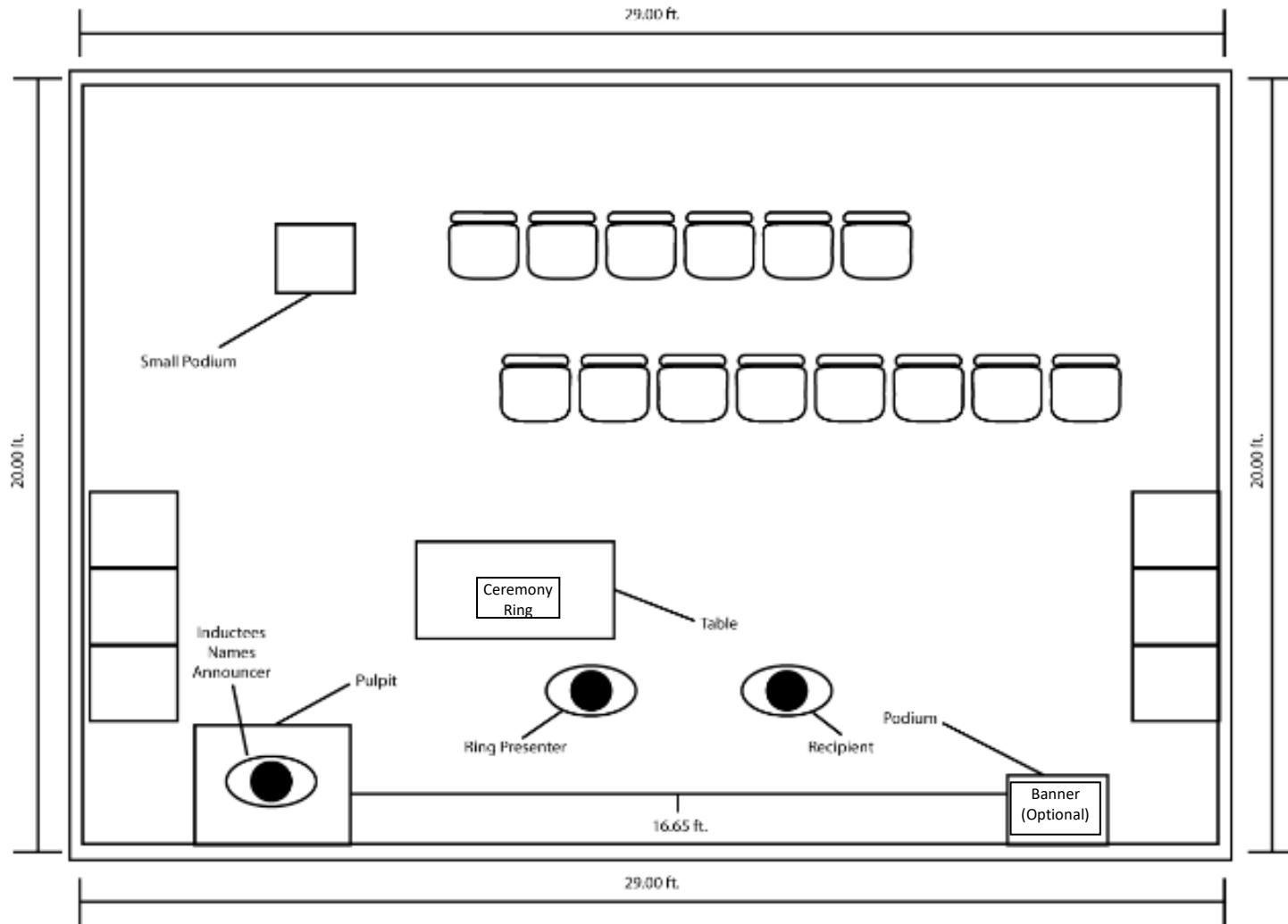

DISTINGUISHED ENGINEERING ALUMNI INDUCTION

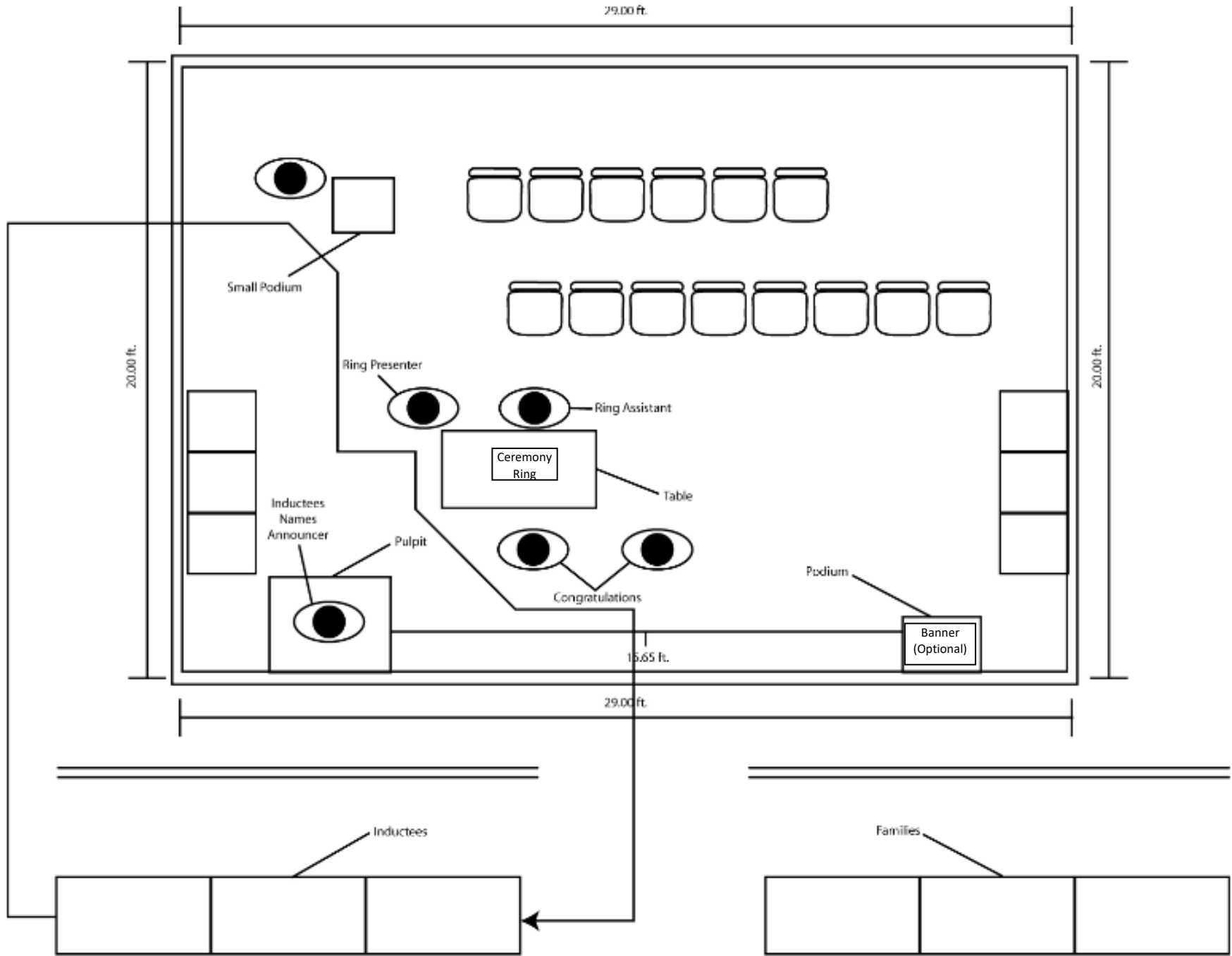

TRAFFIC FLOW FOR THE ORDER OF THE ENGINEER INDUCTION

CEREMONIAL RING SPECIFICATIONS



CEREMONIAL RING FOR THE ORDER OF THE ENGINEER

All links should have a large "ceremonial ring" made of wood or steel, which may be purchased from "The Order", through which inductees place their little finger when receiving their ring.

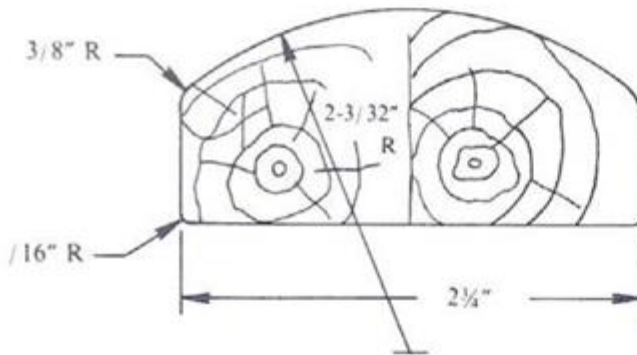

Section through Ring

Finishing Instructions for Ring:

1. Sand smooth.
2. Fill with good grade wood filler.
3. Paint 3 coats plastic engineering #960 aluminum epoxy.

Base:

1. Sand smooth.
2. Fill.
3. Paint flat black.

Suggested Lamination Using White Pine 2x4's

